

Ovens

## Built-In Ovens



MODEL CODE	OIM 25600 XP	OIM 25600 X	OIM 25600 XL	OIM 25500 X
<b>COLOUR OPTIONS</b>				
Stainless steel-X	•	•	•	•
Black-B				
Charcoal-C				
White-W				
CONTROL PANEL TYPE	Metal&Glass	Metal&Glass	Metal&Glass	Metal&Glass
<b>OVEN FEATURES</b>				
Oven type	Multifunction	Multifunction	Multifunction	Multifunction
Control type	Electronic touch control	Electronic touch control	Electronic touch control	Electronic
Door opening type	Drop down	Drop down	Side opening-Left	Drop down
Cooking functions				
1	Conventional	Conventional	Conventional	Conventional
2	Conventional+fan	Conventional+fan	Conventional+fan	Conventional+fan
3	Fan heating	Fan heating	Fan heating	Fan heating
4	Multidimensional cooking	Multidimensional cooking	Multidimensional cooking	Multidimensional cooking
5	Pizza	Pizza	Pizza	Pizza
6	Grill+fan	Grill+fan	Grill+fan	Grill+fan
7	Grill	Grill	Grill	Grill
8	Low grill	Low grill	Low grill	Low grill
9	SlowCook	SlowCook	SlowCook	SlowCook
10	Bottom heater	Bottom heater	Bottom heater	Bottom heater
11	Warm keeping	Warm keeping	Warm keeping	Warm keeping
12	Defrost	Defrost	Defrost	Defrost
Booster	•	•	•	•
Pyrolytic cleaning	•	-	-	•
Eco-pyrolytic cleaning	•	-	-	•
Odour filter	•	•	•	•
Fan heater	•	•	•	•
Fan motor	•	•	•	•
Grill	•	•	•	•
Oven light	Standard	Rectangular+standard	Rectangular+standard	Rectangular+standard
Cavity volume (lt)	65	65	65	65
Timer	Digital	Digital	Digital	Digital
Key Lock	•	•	•	•
Full Glass inner door	Yes-removeable	Yes-removeable	Yes-removeable	Yes-removeable
Catalytic back wall	-	•	•	•
Removeable catalytic side walls	-	-	-	-
Removeable side racks	Yes-5 levels	Yes-5 levels	Yes-5 levels	Yes-5 levels
Fingerprint free stainless steel	-	-	-	-
Telescopic shelf system	-	Yes-1 level	Yes-1 level	Yes-1 level
Electronic ignition (for gas oven)	N/A	N/A	N/A	N/A
Turnspit	-	-	-	•
Number of door Glass	4	2	2	4
Cool Door	•	-	-	•
<b>ACCESSORIES</b>				
Cooking tray				1
Deep tray	1	1	1	1
Baking tray	1	1		
Wire shelf	1	1	1	1
<b>PERFORMANCE &amp; ENERGY CONNECTIONS</b>				
Energy efficiency class	A	A	A	A
Energy consumption for conventional heating (kWh)	0.88	0.88	0.88	0.88
fan heating (kWh)	0.79	0.79	0.79	0.79
Noise level (dba)	46	46	46	46
Gas type and pressure	N/A	N/A	N/A	N/A
Voltage (V)	220-240	220-240	220-240	220-240
Frequency (Hz)	50	50	50	50
Supply cord	•	•	•	•
Plug	-	-	-	-
<b>DIMENSIONS</b>				
Under counter dimensions (hxwx) (cm)	60x56x55	60x56x55	60x56x55	60x56x55
Cabinet dimensions (hxwx) (cm)	59x56x55	59x56x55	59x56x55	59x56x55
Product dimensions (hxwx) (cm)	59.5x59.4x56.7	59.5x59.4x56.7	59.5x59.4x56.7	59.5x59.4x56.7

## Built-In Ovens



MODEL CODE	OIM 25500 XP	OIM 25501 X	OIM 25500 XL	OIE 25500 X
<b>COLOUR OPTIONS</b>				
Stainless steel-X	•	•	•	•
Black-B				
Charcoal-C				
White-W				
CONTROL PANEL TYPE	Metal&Glass	Metal&Glass	Metal&Glass	Metal&Glass
<b>OVEN FEATURES</b>				
Oven type	Multifunction	Multifunction	Multifunction	Multifunction
Control type	Electronic	Electronic	Electronic	Electronic
Door opening type	Drop down	Drop down	Side opening-Left	Drop down
Cooking functions				
1	Conventional	Conventional	Conventional	Conventional
2	Conventional+fan	Conventional+fan	Conventional+fan	Conventional+fan
3	Fan heating	Fan heating	Fan heating	Grill+fan
4	Multidimensional cooking	Multidimensional cooking	Multidimensional cooking	Grill
5	Pizza	Pizza	Pizza	Low grill
6	Grill+fan	Grill+fan	Grill+fan	Bottom heater
7	Grill	Grill	Grill	Warm keeping
8	Low grill	Low grill	Low grill	Defrost
9	SlowCook	SlowCook	SlowCook	-
10	Bottom heater	Bottom heater	Bottom heater	-
11	Warm keeping	Warm keeping	Warm keeping	-
12	Defrost	Defrost	Defrost	-
Booster	•	•	•	•
Pyrolytic cleaning	•	•	-	-
Eco-pyrolytic cleaning	•	•	-	-
Odour filter	•	•	•	•
Fan heater	•	•	•	-
Fan motor	•	•	•	•
Grill	•	•	•	•
Oven light	Standard	Rectangular+standard	Rectangular+standard	Standard
Cavity volume (lt)	65	65	65	65
Timer	Digital	Digital	Digital	Digital
Key Lock	•	•	•	•
Full Glass inner door	Yes-removeable	Yes-removeable	Yes-removeable	Yes
Catalytic back wall	-	•	•	•
Removeable catalytic side walls	-	-	-	-
Removeable side racks	Yes-5 levels	Yes-5 levels	Yes-5 levels	Yes-5 levels
Fingerprint free stainless steel	•	•	•	•
Telescopic shelf system	-	Yes-1 level	Yes-1 level	-
Electronic ignition (for gas oven)	N/A	N/A	N/A	N/A
Turnspit	-	-	-	-
Number of door Glass	4	2	2	2
Cool Door	•	•	-	-
<b>ACCESSORIES</b>				
Cooking tray	1	1	1	
Deep tray	1	1	1	1
Baking tray				1
Wire shelf	1	1	1	1
<b>PERFORMANCE &amp; ENERGY CONNECTIONS</b>				
Energy efficiency class	A	A	A	A
Energy consumption for conventional heating (kWh)	0.88	0.88	0.88	0.88
fan heating (kWh)	0.79	0.79	0.79	0.79
Noise level (dba)	46	46	46	46
Gas type and pressure	N/A	N/A	N/A	N/A
Voltage (V)	220-240	220-240	220-240	220-240
Frequency (Hz)	50	50	50	50
Supply cord	•	•	•	•
Plug	-	-	-	-
<b>DIMENSIONS</b>				
Under counter dimensions (hxwx) (cm)	60x56x55	60x56x55	60x56x55	60x56x55
Cabinet dimensions (hxwx) (cm)	59x56x55	59x56x55	59x56x55	59x56x55
Product dimensions (hxwx) (cm)	59.5x59.4x56.7	59.5x59.4x56.7	59.5x59.4x56.7	59.5x59.4x56.7

## Built-In Ovens



MODEL CODE	OIM 24500 BP/WP	OIM 24500 B	OIM 24500 W	OIM 22500 XP
<b>COLOUR OPTIONS</b>				
Stainless steel-X	.	.	.	.
Black-B	.	.	.	.
Charcoal-C	.	.	.	.
White-W	.	.	.	.
CONTROL PANEL TYPE	Glass	Glass	Glass	Metal
<b>OVEN FEATURES</b>				
Oven type	Multifunction	Multifunction	Multifunction	Multifunction
Control type	Electronic	Electronic	Electronic	Electronic
Door opening type	Drop down	Drop down	Drop down	Drop down
Cooking functions				
1	Conventional	Conventional	Conventional	Conventional
2	Conventional+fan	Conventional+fan	Conventional+fan	Conventional+fan
3	Fan heating	Fan heating	Fan heating	Fan heating
4	Multidimensional cooking	Multidimensional cooking	Multidimensional cooking	Multidimensional cooking
5	Pizza	Pizza	Pizza	Pizza
6	Grill+fan	Grill+fan	Grill+fan	Grill+fan
7	Grill	Grill	Grill	Grill
8	Low grill	Low grill	Low grill	Low grill
9	SlowCook	SlowCook	SlowCook	SlowCook
10	Bottom heater	Bottom heater	Bottom heater	Bottom heater
11	Warm keeping	Warm keeping	Warm keeping	Warm keeping
12	Defrost	Defrost	Defrost	Defrost
Booster	.	.	.	.
Pyrolytic cleaning	.	-	-	.
Eco-pyrolytic cleaning	.	-	-	.
Odour filter	.	.	.	.
Fan heater	.	.	.	.
Fan motor	.	.	.	.
Grill	.	.	.	.
Oven light	Standard	Standard	Standard	Standard
Cavity volume (lt)	65	65	65	65
Timer	Digital	Digital	Digital	Digital
Key Lock	.	.	.	.
Full Glass inner door	Yes-removeable	Yes-removeable	Yes-removeable	Yes-removeable
Catalytic back wall	-	.	.	-
Removeable catalytic side walls	-	-	-	-
Removeable side racks	Yes-5 levels	Yes-5 levels	Yes-5 levels	Yes-5 levels
Fingerprint free stainless steel	-	-	-	.
Telescopic shelf system	-	Yes-1 level	-	-
Electronic ignition (for gas oven)	N/A	N/A	N/A	N/A
Turnspit	-	-	-	-
Number of door Glass	4	2	2	4
Cool Door	.	-	-	.
<b>ACCESSORIES</b>				
Cooking tray				
Deep tray	1	1	1	1
Baking tray	1	1	1	1
Wire shelf	1	1	1	1
<b>PERFORMANCE &amp; ENERGY CONNECTIONS</b>				
Energy efficiency class	A	A	A	A
Energy consumption for conventional heating (kWh)	0.88	0.88	0.88	0.88
fan heating (kWh)	0.79	0.79	0.79	0.79
Noise level (dba)	46	46	46	46
Gas type and pressure	N/A	N/A	N/A	N/A
Voltage (V)	220-240	220-240	220-240	220-240
Frequency (Hz)	50	50	50	50
Supply cord	.	.	.	.
Plug	-	-	-	-
<b>DIMENSIONS</b>				
Under counter dimensions (hxwx) (cm)	60x56x55	60x56x55	60x56x55	60x56x55
Cabinet dimensions (hxwx) (cm)	59x56x55	59x56x55	59x56x55	59x56x55
Product dimensions (hxwx) (cm)	59.5x59.4x56.7	59.5x59.4x56.7	59.5x59.4x56.7	59.5x59.4x56.7

## Built-In Ovens



MODEL CODE	OIM 22500 X	OIM 22500 XL	OIE 22500 X	OIM 25300 X
<b>COLOUR OPTIONS</b>				
Stainless steel-X	.	.	.	.
Black-B	.	.	.	.
Charcoal-C	.	.	.	.
White-W	.	.	.	.
CONTROL PANEL TYPE	Metal	Metal	Metal	Metal&Glass
<b>OVEN FEATURES</b>				
Oven type	Multifunction	Multifunction	Multifunction	Multifunction
Control type	Electronic	Electronic	Electronic	Mechanic
Door opening type	Drop down	Side opening-Left	Drop down	Drop down
Cooking functions				
1	Conventional	Conventional	Conventional	Defrost
2	Conventional+fan	Conventional+fan	Conventional+fan	Conventional
3	Fan heating	Fan heating	Grill+fan	Conventional+fan
4	Multidimensional cooking	Multidimensional cooking	Grill	Fan heating
5	Pizza	Pizza	Low grill	Bottom heater
6	Grill+fan	Grill+fan	Bottom heater	Low grill+fan
7	Grill	Grill	Warm keeping	Grill
8	Low grill	Low grill	Defrost	Multidimensional cooking
9	SlowCook	SlowCook	-	-
10	Bottom heater	Bottom heater	-	-
11	Warm keeping	Warm keeping	-	-
12	Defrost	Defrost	-	-
Booster	.	.	.	-
Pyrolytic cleaning	-	-	-	-
Eco-pyrolytic cleaning	-	-	-	-
Odour filter	.	.	.	.
Fan heater	.	.	-	.
Fan motor	.	.	.	.
Grill	.	.	.	.
Oven light	Rectangular+standard	Rectangular+standard	Standard	Standard
Cavity volume (lt)	65	65	65	65
Timer	Digital	Digital	Digital	Digital
Key Lock	.	.	.	.
Full Glass inner door	Yes-removeable	Yes-removeable	Yes	Yes
Catalytic back wall	.	.	-	-
Removeable catalytic side walls	-	-	-	-
Removeable side racks	Yes-5 levels	Yes-5 levels	Yes-5 levels	Yes-5 levels
Fingerprint free stainless steel	.	.	-	-
Telescopic shelf system	-	Yes-1 level	-	-
Electronic ignition (for gas oven)	N/A	N/A	N/A	N/A
Turnspit	-	-	-	-
Number of door Glass	2	2	2	2
Cool Door	-	-	-	-
<b>ACCESSORIES</b>				
Cooking tray				1
Deep tray	1	1	1	
Baking tray	1	1	1	1
Wire shelf	1	1	1	1
<b>PERFORMANCE &amp; ENERGY CONNECTIONS</b>				
Energy efficiency class	A	A	A	A
Energy consumption for conventional heating (kWh)	0.88	0.88	0.88	0.88
fan heating (kWh)	0.79	0.79	0.79	0.79
Noise level (dba)	46	46	46	46
Gas type and pressure	N/A	N/A	N/A	N/A
Voltage (V)	220-240	220-240	220-240	220-240
Frequency (Hz)	50	50	50	50
Supply cord	.	.	.	.
Plug	-	-	-	-
<b>DIMENSIONS</b>				
Under counter dimensions (hxwx) (cm)	60x56x55	60x56x55	60x56x55	60x56x55
Cabinet dimensions (hxwx) (cm)	59x56x55	59x56x55	59x56x55	59x56x55
Product dimensions (hxwx) (cm)	59.5x59.4x56.7	59.5x59.4x56.7	59.5x59.4x56.7	59.5x59.4x56.7

## Built-In Ovens



MODEL CODE	OIM 22300 X	OIE 22300 X	OIE 24300 B	OIE 24300 W
<b>COLOUR OPTIONS</b>				
Stainless steel-X	•	•	•	•
Black-B				
Charcoal-C				
White-W				•
CONTROL PANEL TYPE	Metal	Metal	Glass	Glass
<b>OVEN FEATURES</b>				
Oven type	Multifunction	Multifunction	Multifunction	Multifunction
Control type	Mechanic	Mechanic	Mechanic	Mechanic
Door opening type	Drop down	Drop down	Drop down	Drop down
Cooking functions				
1	Defrost	Conventional+fan	Conventional+fan	Conventional+fan
2	Conventional	Conventional	Conventional	Conventional
3	Conventional+fan	Bottom heater	Bottom heater	Bottom heater
4	Fan heating	Low grill+fan	Low grill+fan	Low grill+fan
5	Bottom heater	Grill	Grill	Grill
6	Low grill+fan	Booster	Booster	Booster
7	Grill	-	-	-
8	Multidimensional cooking	-	-	-
9	-	-	-	-
10	-	-	-	-
11	-	-	-	-
12	-	-	-	-
Booster	-	•	•	•
Pyrolytic cleaning	-	-	-	-
Eco-pyrolytic cleaning	-	-	-	-
Odour filter	-	-	-	-
Fan heater	•	-	-	-
Fan motor	•	•	•	•
Grill	•	•	•	•
Oven light	Standard	Standard	Standard	Standard
Cavity volume (lt)	65	65	65	65
Timer	Digital	Digital	Digital	Digital
Key Lock	-	-	-	-
Full Glass inner door	Yes	Yes	Yes	Yes
Catalytic back wall	-	-	-	-
Removeable catalytic side walls	-	-	-	-
Removeable side racks	-	Yes-5 levels	Yes-5 levels	Yes-5 levels
Fingerprint free stainless steel	-	-	-	-
Telescopic shelf system	-	-	-	-
Electronic ignition (for gas oven)	N/A	N/A	N/A	N/A
Turnspit	-	-	-	-
Number of door Glass	2	2	2	2
Cool Door	-	-	-	-
<b>ACCESSORIES</b>				
Cooking tray	1	1	1	1
Deep tray	-	1	1	1
Baking tray	1	-	-	-
Wire shelf	1	1	1	1
<b>PERFORMANCE &amp; ENERGY CONNECTIONS</b>				
Energy efficiency class	A	A	A	A
Energy consumption for conventional heating (kWh)	0.88	0.88	0.88	0.88
fan heating (kWh)	0.79	0.79	0.79	0.79
Noise level (dba)	46	46	46	46
Gas type and pressure	N/A	N/A	N/A	N/A
Voltage (V)	220-240	220-240	220-240	220-240
Frequency (Hz)	50	50	50	50
Supply cord	•	•	•	•
Plug	-	-	-	-
<b>DIMENSIONS</b>				
Under counter dimensions (hxwx) (cm)	60x56x55	60x56x55	60x56x55	60x56x55
Cabinet dimensions (hxwx) (cm)	59x56x55	59x56x55	59x56x55	59x56x55
Product dimensions (hxwx) (cm)	59.5x59.4x56.7	59.5x59.4x56.7	59.5x59.4x56.7	59.5x59.4x56.7

## Built-In Ovens



MODEL CODE	OIM 22100 X	OIE 22101 X	OIE 22100 X	OIE 22000 X
<b>COLOUR OPTIONS</b>				
Stainless steel-X	•	•	•	•
Black-B				
Charcoal-C				
White-W				
CONTROL PANEL TYPE	Metal	Metal	Metal	Metal
<b>OVEN FEATURES</b>				
Oven type	Multifunction	Multifunction	Multifunction	Multifunction
Control type	Mechanic	Mechanic	Mechanic	Mechanic
Door opening type	Drop down	Drop down	Drop down	Drop down
Cooking functions				
1	Defrost	Conventional+fan	Conventional+fan	Conventional+fan
2	Conventional	Conventional	Conventional	Conventional
3	Conventional+fan	Bottom heater	Bottom heater	Bottom heater
4	Fan heating	Low grill+fan	Low grill+fan	Low grill+fan
5	Bottom heater	Grill	Grill	Grill
6	Low grill+fan	Booster	Booster	Booster
7	Grill	-	-	-
8	Multidimensional cooking	-	-	-
9	-	-	-	-
10	-	-	-	-
11	-	-	-	-
12	-	-	-	-
Booster	-	•	•	•
Pyrolytic cleaning	-	-	-	-
Eco-pyrolytic cleaning	-	-	-	-
Odour filter	-	-	-	-
Fan heater	•	-	-	-
Fan motor	•	•	•	•
Grill	•	•	•	•
Oven light	Standard	Standard	Standard	Standard
Cavity volume (lt)	65	65	65	65
Timer	Mechanic-programmable	Mechanic-programmable	Mechanic-programmable	-
Key Lock	-	-	-	-
Full Glass inner door	Yes	Yes	Yes	Yes
Catalytic back wall	-	-	-	-
Removeable catalytic side walls	-	-	-	-
Removeable side racks	Yes-3 levels	Yes-3 levels	-	-
Fingerprint free stainless steel	-	-	-	-
Telescopic shelf system	-	-	-	-
Electronic ignition (for gas oven)	N/A	N/A	N/A	N/A
Turnspit	-	-	-	-
Number of door Glass	2	2	2	2
Cool Door	-	-	-	-
<b>ACCESSORIES</b>				
Cooking tray	1	1	1	1
Deep tray	-	1	-	-
Baking tray	1	-	1	-
Wire shelf	1	1	1	1
<b>PERFORMANCE &amp; ENERGY CONNECTIONS</b>				
Energy efficiency class	A	A	A	A
Energy consumption for conventional heating (kWh)	0.88	0.88	0.88	0.88
fan heating (kWh)	0.79	0.79	0.79	0.79
Noise level (dba)	46	46	46	46
Gas type and pressure	N/A	N/A	N/A	N/A
Voltage (V)	220-240	220-240	220-240	220-240
Frequency (Hz)	50	50	50	50
Supply cord	•	•	•	•
Plug	-	-	-	-
<b>DIMENSIONS</b>				
Under counter dimensions (hxwx) (cm)	60x56x55	60x56x55	60x56x55	60x56x55
Cabinet dimensions (hxwx) (cm)	59x56x55	59x56x55	59x56x55	59x56x55
Product dimensions (hxwx) (cm)	59.5x59.4x56.7	59.5x59.4x56.7	59.5x59.4x56.7	59.5x59.4x56.7

## Built-In Ovens



MODEL CODE	OIC 22101 X	OIC 22100 X	OIC 22000 X	OIC 21000 X/W
<b>COLOUR OPTIONS</b>				
Stainless steel-X	•	•	•	•
Black-B				
Charcoal-C				
White-W				•
CONTROL PANEL TYPE	Metal	Metal	Metal	Metal
<b>OVEN FEATURES</b>				
Oven type	Conventional	Conventional	Conventional	Conventional
Control type	Mechanic	Mechanic	Mechanic	Mechanic
Door opening type	Drop down	Drop down	Drop down	Drop down
Cooking functions				
1	Conventional	Conventional	Conventional	Conventional
2	Bottom heater	Bottom heater	Bottom heater	Bottom heater
3	Low grill	Low grill	Low grill	Low grill
4	Grill	Grill	Grill	Grill
5	-	-	-	-
6	-	-	-	-
7	-	-	-	-
8	-	-	-	-
9	-	-	-	-
10	-	-	-	-
11	-	-	-	-
12	-	-	-	-
Booster	-	-	-	-
Pyrolytic cleaning	-	-	-	-
Eco-pyrolytic cleaning	-	-	-	-
Odour filter	-	-	-	-
Fan heater	-	-	-	-
Fan motor	-	-	-	-
Grill	•	•	•	•
Oven light	Standard	Standard	Standard	Standard
Cavity volume (lt)	67.5	67.5	67.5	67.5
Timer	Mechanic-programmable	Mechanic-programmable	-	-
Key Lock	-	-	-	-
Full Glass inner door	Yes	Yes	Yes	Yes
Catalytic back wall	-	-	-	-
Removeable catalytic side walls	Yes	-	-	-
Removeable side racks	Yes-3 levels	-	-	-
Fingerprint free stainless steel	-	-	-	-
Telescopic shelf system	-	-	-	-
Electronic ignition (for gas oven)	N/A	N/A	N/A	N/A
Turnspit	-	-	-	-
Number of door Glass	2	2	2	2
Cool Door	-	-	-	-
<b>ACCESSORIES</b>				
Cooking tray	1	1	1	1
Deep tray	-	-	-	-
Baking tray	-	-	-	-
Wire shelf	1	1	1	1
<b>PERFORMANCE &amp; ENERGY CONNECTIONS</b>				
Energy efficiency class	A	A	A	A
Energy consumption for conventional heating (kWh)	0.88	0.88	0.88	0.88
fan heating (kWh)	-	-	-	-
Noise level (dba)	46	46	46	46
Gas type and pressure	N/A	N/A	N/A	N/A
Voltage (V)	220-240	220-240	220-240	220-240
Frequency (Hz)	50	50	50	50
Supply cord	•	•	•	•
Plug	-	-	-	-
<b>DIMENSIONS</b>				
Under counter dimensions (hxwxd) (cm)	60x56x55	60x56x55	60x56x55	60x56x55
Cabinet dimensions (hxwxd) (cm)	59x56x55	59x56x55	59x56x55	59x56x55
Product dimensions (hxwxd) (cm)	59.5x59.4x56.7	59.5x59.4x56.7	59.5x59.4x56.7	59.5x59.4x56.7

## Built-In Ovens



MODEL CODE	OIE 21200 CU/WU	OIG 12101 X	OIG 12100 X	OIW 19900 X
<b>COLOUR OPTIONS</b>				
Stainless steel-X		•	•	•
Black-B				
Charcoal-C	•			
White-W	•			
CONTROL PANEL TYPE	Metal-Rustic	Metal	Metal	Metal
<b>OVEN FEATURES</b>				
Oven type	Multifunction	Gas	Gas	Multifunction
Control type	Mechanic	Gas thermostat	Gas thermostat	Mechanic
Door opening type	Drop down	Drop down	Drop down	Drop down
Cooking functions				
1	Conventional+fan	Gas	Gas	Oven Light
2	Conventional	-	-	Conventional
3	Bottom heater	-	-	Bottom Heater
4	Low grill+fan	-	-	Upper Heater
5	Grill	-	-	Grill
6	-	-	-	Grill+fan
7	-	-	-	Conventional+fan
8	-	-	-	Multidimensional cooking
9	-	-	-	Defrost
10	-	-	-	
11	-	-	-	
12	-	-	-	
Booster	•	-	-	
Pyrolytic cleaning	-	N/A	N/A	N/A
Eco-pyrolytic cleaning	-	N/A	N/A	N/A
Odour filter	-	-	-	-
Fan heater	-	N/A	N/A	-
Fan motor	•	N/A	N/A	•
Grill	•	Electric grill	Gas grill	•
Oven light	Standard	Standard	Standard	Standard
Cavity volume (lt)	65	49	40	100
Timer	Analog-programmable	Mechanic	Mechanic	Digital
Key Lock	-	N/A	N/A	•
Full Glass inner door	Yes	-	-	-
Catalytic back wall	-	-	-	-
Removeable catalytic side walls	-	-	-	-
Removeable side racks	Yes-5 levels	Yes-3 levels	Yes-3 levels	Yes-3 levels
Fingerprint free stainless steel	-	-	-	-
Telescopic shelf system	-	-	-	-
Electronic ignition (for gas oven)	N/A	•	•	•
Turnspit	-	•	•	•
Number of door Glass	2	2	2	2
Cool Door	-	-	-	-
<b>ACCESSORIES</b>				
Cooking tray	1	1	1	1
Deep tray	1	-	-	-
Baking tray	-	-	-	-
Wire shelf	1	1	1	1
<b>PERFORMANCE &amp; ENERGY CONNECTIONS</b>				
Energy efficiency class	A	N/A	N/A	B
Energy consumption for conventional heating (kWh)	0.88	-	-	-
fan heating (kWh)	0.79	-	-	-
Noise level (dba)	46	-	-	-
Gas type and pressure	N/A	G20-20mbar Natural	G20-20mbar Natural	-
Voltage (V)	220-240	220-230	220-230	230
Frequency (Hz)	50	50	50	50
Supply cord	•	•	•	•
Plug	-	•	•	-
<b>DIMENSIONS</b>				
Under counter dimensions (hxwxd) (cm)	60x56x55	59.5x56x55	59.5x56x55	
Cabinet dimensions (hxwxd) (cm)	59x56x55	58.5x55x55	58.5x55x55	47.8x86x56
Product dimensions (hxwxd) (cm)	59.5x59.4x56.7	59.4x59.6x54	59.4x59.6x54	48x89.8x56.3

OIM 25600 XP | OIM 25600 X | OIM 25600 XL | OIM 25500 X | OIM 25500XP | OIM 25501 X  
 OIM 25500 XL | OIE 25500 X | OIM 24500 BP/WP | OIM 24500 B | OIM 24500 W | OIM 22500 XP  
 OIM 22500 X | OIM 22500 XL | OIE 22500 X | OIM 25300 X | OIM 22300 X | OIE 22300 X  
 OIE 24300 B | OIE 24300 W | OIM 22100 X | OIE 22101 X | OIE 22100 X | OIE 22000 X  
 OIC 22101 X | OIC 22100 X | OIC 22000 X | OIC 21000 X/W | OIE 21200 CU/WU

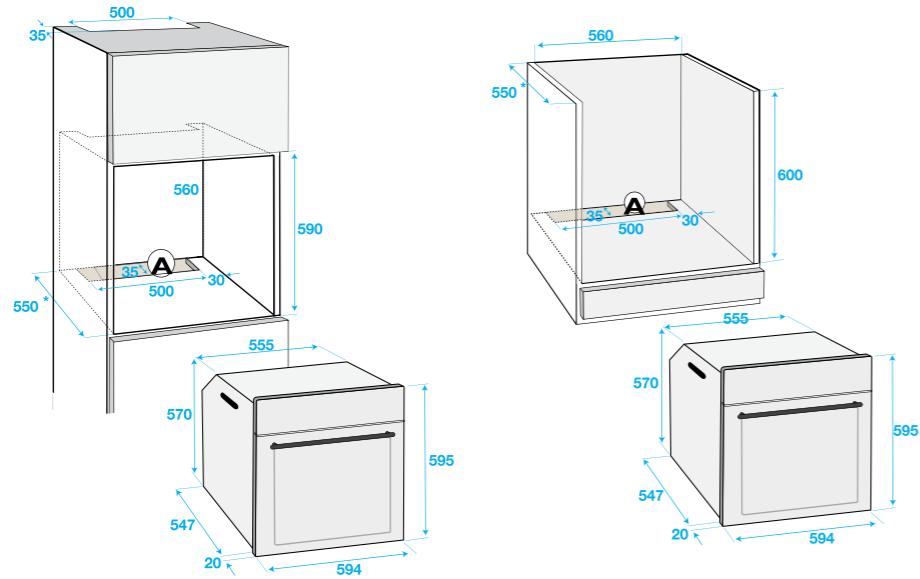

OIG 12101x | OIG 12100x

OIW 19900x

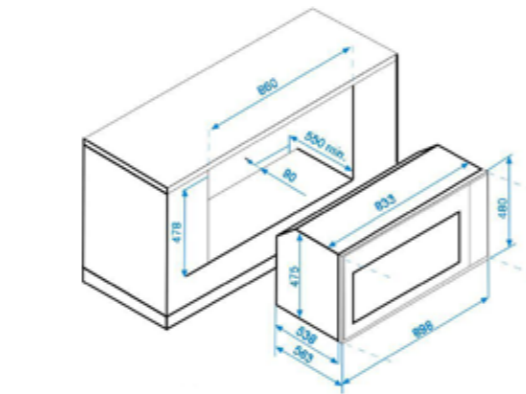
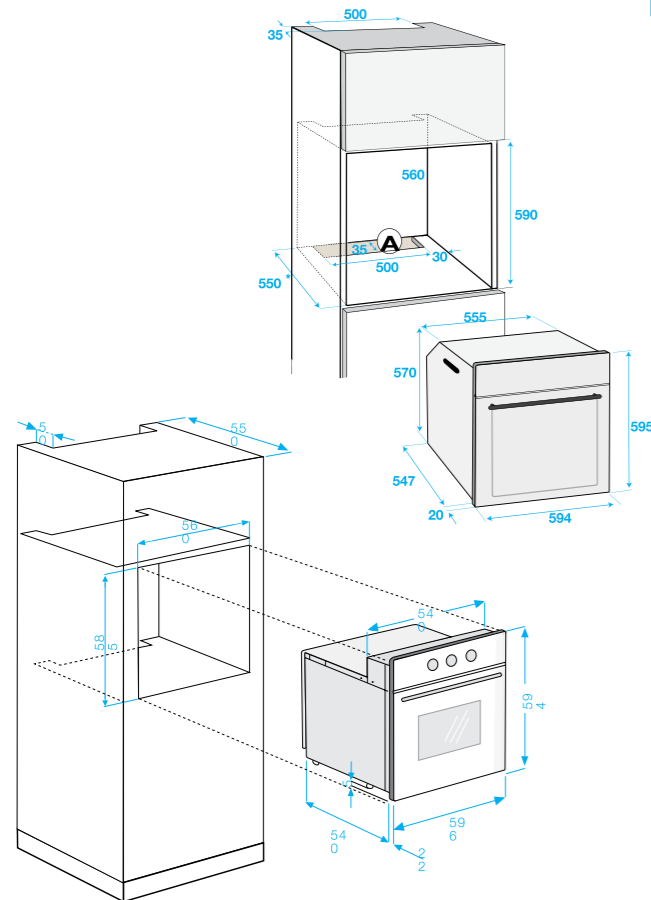

## Built-Under Ovens



MODEL CODE	OUM 25520 X	OUM 22520 X	OUM 22320 X/W	OUE 22320 X
<b>COLOUR</b>				
<b>Oven</b>				
Stainless steel-X	•	•	•	•
Black-B				
Charcoal-C				
White-W			•	
<b>Hob</b>				
Stainless steel-X	•	•	•	
Black-B				
White-W				
<b>HOB FEATURES</b>				
Hob type	Vitroc ceramic	Vitroc ceramic	Vitroc ceramic	Vitroc ceramic
Number of zones	4	4	4	4
Zone diameter (mm) and power (kW)				
Front left	180/120mm-1,7/0,7 kW	180/120mm-1,7/0,7 kW	180/120mm-1,7/0,7 kW	180/120mm-1,7/0,7 kW
Rear left	DUO hi light	DUO hi light	DUO hi light	DUO hi light
Front Right	140mm-1,2 kW	140mm-1,2 kW	140mm-1,2 kW	140mm-1,2 kW
Rear right	140mm-1,2 kW	140mm-1,2 kW	140mm-1,2 kW	140mm-1,2 kW
Frame	170/265mm-2,4/1,5 kW extended hi light	180mm-1,7 Kw	170/265mm-2,4/1,5 kW extended hi light	180mm-1,7 Kw
Frame	InoxFrame	No Frame	InoxFrame	No Frame
<b>CONTROL PANEL TYPE</b>				
Control panel type	Metal&Glass	Metal	Metal	Metal
<b>OVEN FEATURES</b>				
Oven type	Multifunction	Multifunction	Multifunction	Multifunction
Control type	Electronic	Electronic	Mechanic	Mechanic
Door opening type	Drop down	Drop down	Drop down	Drop down
Cooking functions				
1	Conventional	Conventional	Defrost	Conventional+fan
2	Conventional+fan	Conventional+fan	Conventional	Conventional
3	Fan heating	Fan heating	Conventional+fan	Bottom heater
4	Multidimensional cooking	Multidimensional cooking	Fan heating	Low grill+fan
5	Pizza	Pizza	Bottom heater	Grill
6	Grill+fan	Grill+fan	Low grill+fan	Booster
7	Grill	Grill	Grill	-
8	Low grill	Low grill	Multidimensional cooking	-
9	SlowCook	SlowCook	-	-
10	Bottom heater	Bottom heater	-	-
11	Warm keeping	Warm keeping	-	-
12	Defrost	Defrost	-	-
Booster	•	•	-	•
Pyrolytic cleaning	-	-	-	-
Eco-pyrolytic cleaning	-	-	-	-
Fan heater	•	•	•	•
Fan motor	•	•	•	•
Grill	•	•	•	•
Oven light	Standard	Standard	Standard	Standard
Cavity volume (lt)	65	65	65	65
Timer	Digital	Digital	Digital	Digital
Key Lock	•	•	•	•
Full Glass inner door	Yes-removeable	Yes-removeable	Yes	Yes
Catalytic back wall	•	•	-	-
Removeable catalytic side walls	-	-	-	-
Removeable side racks	Yes-5 levels	Yes-5 levels	-	Yes-5 levels
Telescopic shelf system	-	-	-	-
Turnspit	•	•	-	-
Number of door Glass	2	2	2	2
Cool Door	-	-	-	-
<b>ACCESSORIES</b>				
Cooking tray	1	1	1	1
Deep tray	1	1	-	1
Baking tray	-	-	1	-
Wire shelf	1	1	1	1
<b>PERFORMANCE &amp; ENERGY CONNECTIONS</b>				
Energy efficiency class	A	A	A	A
Energy consumption for				
Conventional heating (kWh)	0.88	0.88	0.88	0.88
Fan heating (kWh)	0.79	0.79	0.79	0.79
Noise level (dba)	46	46	46	45
Voltage (V)	220-240	220-240	220-240	220-240
Frequency (Hz)	50	50	50	50
Supply cord	-	-	-	-
Plug	-	-	-	-
<b>DIMENSIONS</b>				
Niche dimensions-oven (hxwxd) (cm)	60x56x55	60x56x55	60x56x55	60x56x55
Niche dimensions-hob (wxd) (cm)	56x49	56x49	56x49	56x49
Product dimensions-oven (hxwxd) (cm)	59,5x59,4x56,7	59,5x59,4x56,7	59,5x59,4x56,7	59,5x59,4x56,7
Product dimensions-hob (wxd) (cm)	58x51	58x51	58x51	58x51

## Built-Under Ovens



MODEL CODE	OUE 22120 X/W	OUE 22020 X	OUC 22020 X	OUC 22010 X
<b>COLOUR</b>				
<b>Oven</b>				
Stainless steel-X	•	•	•	•
Black-B				
Charcoal-C				
White-W	•			
<b>Hob</b>				
Stainless steel-X				•
Black-B				
White-W				
<b>HOB FEATURES</b>				
Hob type	Vitroceraamic	Vitroceraamic	Vitroceraamic	hotplate
Number of zones	4	4	4	4
Zone diameter (mm) and power (kW)				
Front left	180mm-1,7 Kw	180/120mm-1,7/0,7 kW DUO hi light	180mm-1,7 kW	180mm-2,0 kW Rapid
Rear left	140mm-1,2 kW	140mm-1,2 kW	140mm-1,2 kW	145mm-1,0 kW
Front Right	140mm-1,2 kW	140mm-1,2 kW	140mm-1,2 kW	145mm-1,0 kW
Rear right	180mm-1,7 Kw	180mm-1,7 Kw	180mm-1,7 kW	180mm-2,0 kW Rapid
Frame	No Frame	No Frame		
<b>CONTROL PANEL TYPE</b>	Metal	Metal	Metal	Metal
<b>OVEN FEATURES</b>				
Oven type	Multifunction	Multifunction	Conventional	Conventional
Control type	Mechanic	Mechanic	Mechanic	Mechanic
Door opening type	Drop down	Drop down	Drop down	Drop down
Cooking functions				
1	Conventional+fan	Conventional+fan	Conventional	Conventional
2	Conventional	Conventional	Bottom heater	Bottom heater
3	Bottom heater	Bottom heater	Low grill	Low grill
4	Low grill+fan	Low grill+fan	Grill	Grill
5	Grill	Grill	-	-
6	-	Booster	-	-
7	-	-	-	-
8	-	-	-	-
9	-	-	-	-
10	-	-	-	-
11	-	-	-	-
12	-	-	-	-
Booster	•	•	-	-
Pyrolitic cleaning	-	-	-	-
Eco-pyrolitic cleaning	-	-	-	-
Fan heater	-	-	N/A	N/A
Fan motor	•	•	N/A	N/A
Grill	•	•	•	•
Oven light	Standard	Standard	Standard	Standard
Cavity volume (lt)	65	65	67.5	67.5
Timer	Mechanic-programmable	-	-	-
Key Lock	-	-	-	-
Full Glass inner door	Yes	Yes	Yes	Yes
Catalytic back wall	-	-	-	-
Removeable catalytic side walls	-	-	-	-
Removeable side racks	-	-	-	-
Telescopic shelf system	-	-	-	-
Turnspit	-	-	-	-
Number of door Glass	2	2	2	2
Cool Door	-	-	-	-
<b>ACCESSORIES</b>				
Cooking tray	1	1	1	1
Deep tray	1			
Baking tray		1		
Wire shelf	1	1	1	1
<b>PERFORMANCE &amp; ENERGY CONNECTIONS</b>				
Energy efficiency class	A	A	A	A
Energy consumption for				
Conventional heating (kWh)	0.88	0.88	0.88	0.88
Fan heating (kWh)	0.79	0.79		
Noise level (dba)	45	45	46	46
Voltage (V)	220-240	220-240	220-240	220-240
Frequency (Hz)	50	50	50	50
Supply cord	-	-	-	-
Plug	-	-	-	-
<b>DIMENSIONS</b>				
Niche dimensions-oven (hxwxd) (cm)	60x56x55	60x56x55	60x56x55	60x56x55
Niche dimensions-hob (wxd) (cm)	56x49	56x49	56x49	56x49
Product dimensions-oven (hxwxd) (cm)	59,5x59,4x56,7	59,5x59,4x56,7	59,5x59,4x56,7	59,5x59,4x56,7
Product dimensions-hob (wxd) (cm)	58x51	58x51	58x51	58x51

## Built-Under Ovens



MODEL CODE	OUE 22001 X	OUC 22000 X/W/B
<b>COLOUR</b>		
<b>Oven</b>		
Stainless steel-X	•	•
Black-B		•
Charcoal-C		
White-W		•
<b>Hob</b>		
Stainless steel-X		
Black-B		
White-W		
<b>HOB FEATURES</b>		
Hob type	-	-
Number of zones		
Zone diameter (mm) and power (kW)		
Front left		
Rear left		
Front Right		
Rear right		
Frame		
<b>CONTROL PANEL TYPE</b>	Metal	Metal
<b>OVEN FEATURES</b>		
Oven type	Multifunction	Conventional
Control type	Mechanic	Mechanic
Door opening type	Drop down	Drop down
Cooking functions		
1	Conventional+fan	Conventional
2	Conventional	Upper heater
3	Bottom heater	Bottom heater
4	Low grill+fan	-
5	Grill	-
6	Booster	-
7	-	-
8	-	-
9	-	-
10	-	-
11	-	-
12	-	-
Booster	•	-
Pyrolitic cleaning	-	-
Eco-pyrolitic cleaning	-	-
Fan heater	-	N/A
Fan motor	•	N/A
Grill	•	-
Oven light	Standard	Standard
Cavity volume (lt)	65	67.5
Timer	-	-
Key Lock	-	-
Full Glass inner door	Yes	Yes
Catalytic back wall	-	-
Removeable catalytic side walls	-	-
Removeable side racks	-	-
Telescopic shelf system	-	-
Turnspit	-	-
Number of door Glass	2	2
Cool Door	-	-
<b>ACCESSORIES</b>		
Cooking tray	1	1
Deep tray		
Baking tray	1	
Wire shelf	1	1
<b>PERFORMANCE &amp; ENERGY CONNECTIONS</b>		
Energy efficiency class	A	A
Energy consumption for		
Conventional heating (kWh)	0.88	0.88
Fan heating (kWh)	0.79	
Noise level (dba)	46	46
Voltage (V)	220-240	220-240
Frequency (Hz)	50	50
Supply cord	-	-
Plug	-	-
<b>DIMENSIONS</b>		
Niche dimensions-oven (hxwxd) (cm)	60x56x55	60x56x55
Niche dimensions-hob (wxd) (cm)	-	-
Product dimensions-oven (hxwxd) (cm)	59,5x59,4x56,7	59,5x59,4x56,7
Product dimensions-hob (wxd) (cm)	-	-

OUM 25520 X | OUM 22520 X | OUM 22320 X/W | OUE 22320 X

OUE 22120 X/W | OUE 22020 X | OUC 22020 X

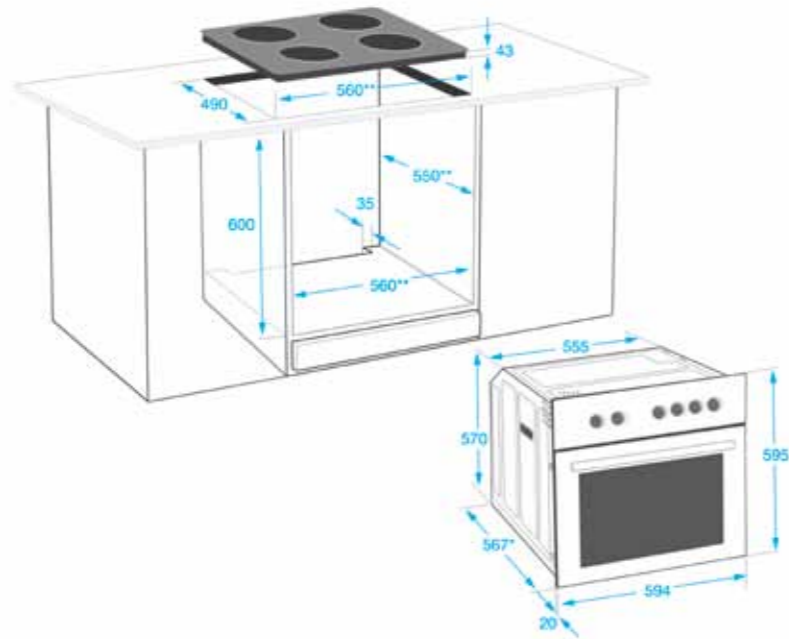

OUC 22010 X

OUE 22001 X | OUC 22000 X/W/B

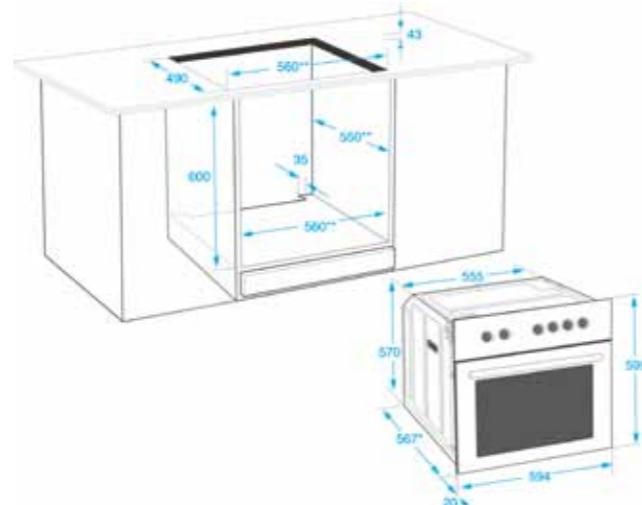
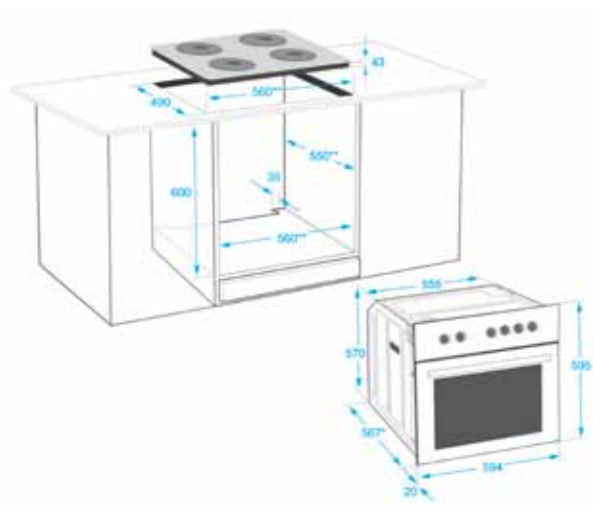

## Compact Ovens



MODEL CODE	OCM 25600 XP	OCM 25600 X	OCM 25500 XP	OCM 25500 X
<b>COLOUR OPTIONS</b>				
Stainless steel-X	.	.	.	.
Black-B	.	.	.	.
Charcoal-C	.	.	.	.
White-W	.	.	.	.
Control panel type	Metal&Glass	Metal&Glass	Metal&Glass	Metal&Glass
<b>OVEN FEATURES</b>				
Oven type	Multifunction	Multifunction	Multifunction	Multifunction
Control type	Electronic touch control	Electronic touch control	Electronic	Electronic
Door opening type	Drop down	Drop down	Drop down	Drop down
Cooking functions				
1	Conventional	Conventional	Conventional	Conventional
2	Conventional+fan	Conventional+fan	Conventional+fan	Conventional+fan
3	Fan heating	Fan heating	Fan heating	Fan heating
4	Multidimensional cooking	Multidimensional cooking	Multidimensional cooking	Multidimensional cooking
5	Pizza	Pizza	Pizza	Pizza
6	Grill+fan	Grill+fan	Grill+fan	Grill+fan
7	Grill	Grill	Grill	Grill
8	Low grill	Low grill	Low grill	Low grill
9	SlowCook	SlowCook	SlowCook	SlowCook
10	Bottom heater	Bottom heater	Bottom heater	Bottom heater
11	Warm keeping	Warm keeping	Warm keeping	Warm keeping
12	Defrost	Defrost	Defrost	Defrost
Booster	.	.	.	.
Pyrolytic cleaning	.	.	.	.
Eco-pyrolytic cleaning	.	.	.	.
Fan heater	.	.	.	.
Fan motor	.	.	.	.
Grill	.	.	.	.
Oven light	Standard	Standard	Standard	Standard
Cavity volume (lt)	45.5	45.5	45.5	45.5
Timer	Digital	Digital	Digital	Digital
Key lock	.	.	.	.
Full Glass inner door	Yes-removeable	Yes-removeable	Yes-removeable	Yes-removeable
Removeable side racks	Yes-3 levels	Yes-3 levels	Yes-3 levels	Yes-3 levels
Telescopic shelf system	-	-	-	-
Number of door Glass	4	2	4	2
Cool Door	.	.	.	.
<b>ACCESSORIES</b>				
Glass tray	.	.	.	.
Baking tray	1	1	1	1
Wire shelf	1	1	1	1
<b>PERFORMANCE &amp; ENERGY CONNECTIONS</b>				
Energy efficiency class	A	A	A	A
Voltage (V)	220-240	220-240	220-240	220-240
Frequency (Hz)	50	50	50	50
Supply cord	.	.	.	.
Plug	-	-	-	-
<b>DIMENSIONS</b>				
Niche dimensions (hxwx) (cm)	45x56x55(Min)	45x56x55(Min)	45x56x55(Min)	45x56x55(Min)
Product dimensions (hxwx) (cm)	45,5x59,4x56,7	45,5x59,4x56,7	45,5x59,4x56,7	45,5x59,4x56,7

OCM 25600 XP | OCM 25600 X | OCM 25500 XP | OCM 25500 X | OCM 22300 X | OCE 22300 X

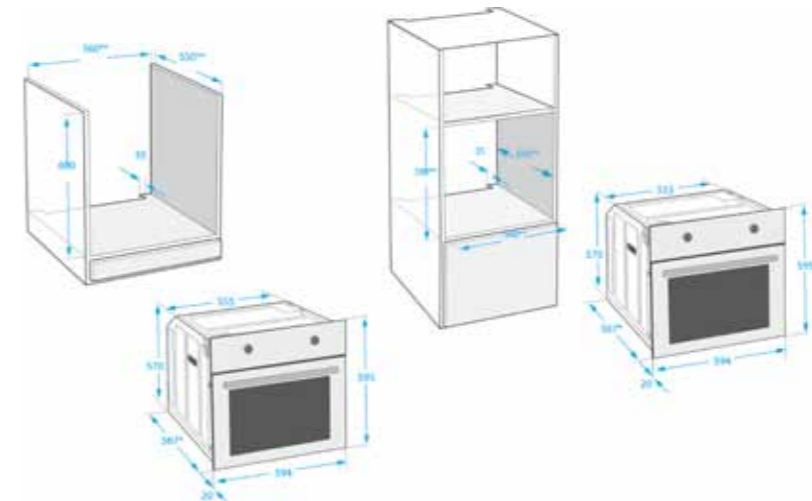



## Compact Ovens



MODEL CODE	OCW 45300 X	OCM 22300 X	OCE 22300 X
<b>COLOUR OPTIONS</b>			
Stainless steel-X	•	•	•
Black-B			
Charcoal-C			
White-W			
Control panel type	Metal&Glass	Metal	Metal
<b>OVEN FEATURES</b>			
Oven type	Microwave+Grill	Multifunction	Multifunction
Control type	Mechanic	Mechanic	Mechanic
Door opening type	Drop down	Drop down	Drop down
Cooking functions			
1	Microwave	Defrost	Conventional+fan
2	Grill	Conventional	Conventional
3	Microwave+Grill	Conventional+fan	Bottom heater
4	Defrost	Fan heating	Low grill+fan
5	Grill+fan+microwave	Bottom heater	Grill
6	Grill+fan	Low grill+fan	Booster
7	-	Grill	-
8	-	Multidimensional cooking	-
9	-	-	-
10	-	-	-
11	-	-	-
12	-	-	-
Booster	•	-	•
Pyrolytic cleaning	-	-	-
Eco-pyrolytic cleaning	-	-	-
Fan heater	-	•	-
Fan motor	•	•	•
Grill	•	•	•
Oven light	Standard	Standard	Standard
Cavity volume (lt)	32	45.5	45.5
Timer	Digital	Digital	Digital
Key lock	•	•	
Full Glass inner door	Yes	Yes	Yes
Removeable side racks	-	Yes-3 levels	Yes-3 levels
Telescopic shelf system	-	-	-
Number of door Glass	2	2	2
Cool Door	-	-	-
<b>ACCESSORIES</b>			
Glass tray	1	-	-
Baking tray	1	1	1
Wire shelf	1	1	1
<b>PERFORMANCE &amp; ENERGY CONNECTIONS</b>			
Energy efficiency class	-	A	A
Voltage (V)	220-240	220-240	220-240
Frequency (Hz)	50	50	50
Supply cord	•	•	•
Plug	-	-	-
<b>DIMENSIONS</b>			
Niche dimensions (hxwx d) (cm)	45x56x55(Min)	45x56x55(Min)	45x56x55(Min)
Product dimensions (hxwx d) (cm)	45,5x59,5x47,2	45,5x59,4x56,7	45,5x59,4x56,7

### OCW 45300 X

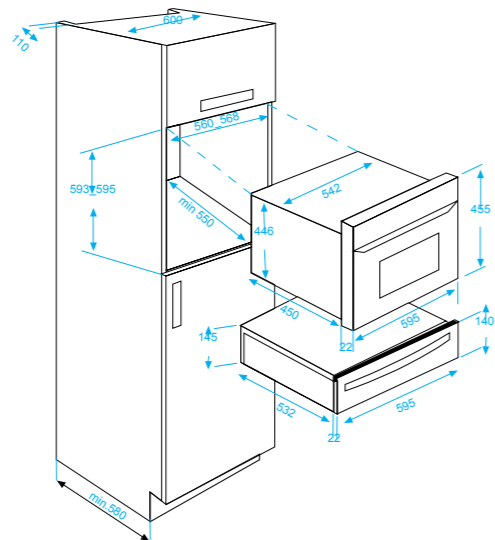

## Warming Drawers



MODEL CODE	DRW 11400 F	DRW 11400 D
<b>COLOUR OPTIONS</b>		
Stainless steel-X	•	•
Black-B	•	-
White-W	•	-
<b>MAIN FEATURES</b>		
Drawer type	Telescopic	Telescopic
Control type	Electronic, knob controlled	Mechanic, knob controlled
Drawer functions	5 functions	1 function
1	Dough raising	Pre-warming crockery & utensils
2	Defrost	
3	Pre-heating of food	
4	Warm keeping of food	
5	Pre-warming crockery & utensils	
Levels of temperature	4 levels-between 40°C and 80°C	3 levels-between 40°C and 70°C
Plates capacity		
	6 serving plates	6 serving plates
	6x24 cm dinner plates	6x24 cm dinner plates
	6x10 cm soup bowls	6x10 cm soup bowls
	1x19 cm serving dish	1x19 cm serving dish
	1x17 cm serving dish	1x17 cm serving dish
	1x32 cm meat plate	1x32 cm meat plate
Warming drawer interior	Stainless steel	Stainless steel
Capacity	25 kg	25 kg
Antifinger print inox	•	-
<b>PERFORMANCE &amp; ENERGY CONNECTIONS</b>		
Rated power (kW)	0.8	0.4
Voltage (V)	220-240	220-240
Frequency (Hz)	50	50
Supply cord	•	•
Plug	•	•
<b>DIMENSIONS</b>		
Niche dimensions (hxwx d) (cm)	(14,3-14,5)x56x55	(14,3-14,5)x56x55
Product dimensions (hxwx d) (cm)	14x59,4x55,5	14x59,4x55,5

### DRW 11400 F | DRW 11400 D

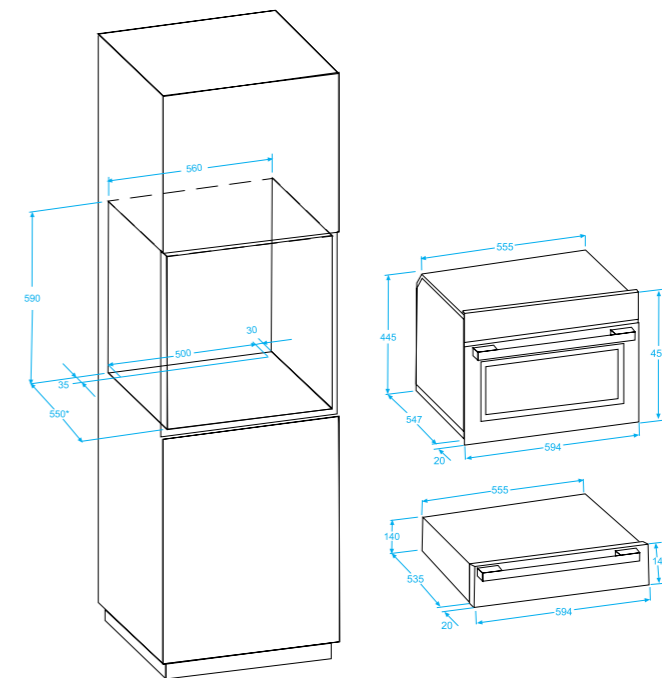

## Microwave Ovens



MODEL CODE	MWB 3010 EX	MWB 2510 EX	MWB 2310 EX	MWB 2000 EX
<b>MAIN FEATURES</b>				
Capacity	30lt	25lt	23lt	20lt
Microwave power	900	900	900	800
Microwave power level	5	5	5	5
Cooking functions	3	3	3	3
Programmable digital timer	·	·	·	·
Microwave oven interior	Stainless steel	Stainless steel	Stainless steel	Painted
Defrost	·	·	·	·
Display on/off	·	·	·	·
Grill	·	·	·	-
Grill power	1200 W	1200 W	1200 W	-
Interior oven light	·	·	·	-
Child lock	·	·	·	·
Day Time on display	·	·	·	·
Time cook	·	·	·	·
<b>APPEARANCE</b>				
Color	Stainless steel	Stainless steel	Stainless steel	Stainless steel
Cookbook	·	·	·	·
Glass turntable	·	·	·	·
Niche dimensions	365x568x550	365x568x550	365x568x550	365x568x550
Product dimensions	300x520x530	310x510x382	310x510x382	282x470x377
Built in frame	Optional	Optional	Optional	Optional
Built in frame code	MWK 3010x	MWK 2510x	MWK 2310x	MWK 2000x
Built in frame dimensions	376x592x42	376x592x42	376x592x42	376x592x42

MWB 3010 EX | MWB 2510 EX | MWB 2310 EX | MWB 2000 EX

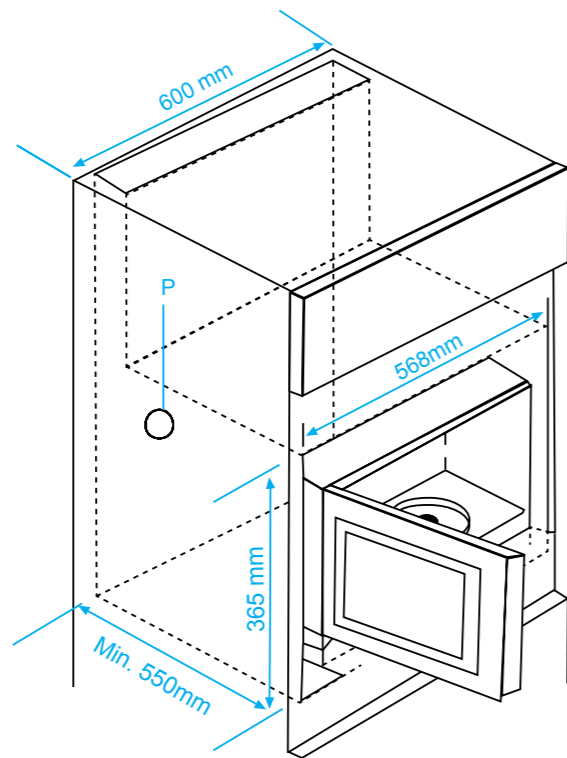

# Hobs

## Induction Hobs



MODEL CODE	HII 64401 T	HII 64400 T	HII 64301 T	HII 64300 T
<b>TYPE</b>				
Hob type	Induction	Induction	Induction	Induction
Width	60 cm	60 cm	60 cm	60 cm
Frame	-	-	-	-
Color options/frame options				
Stainless steel-X	-	-	-	-
White-W	-	-	-	-
Black-B	-	-	-	-
<b>CONTROL</b>				
Control type	Touch control	Touch control	Touch control	Touch control
Control knobs placement	Front	Front	Front	Front
Control level per zone	9 cooking positions	9 cooking positions	9 cooking positions	9 cooking positions
<b>ZONES</b>				
Number of zones & type	4 induction	4 induction	3 induction	3 induction
Zone size (mm) & power (kW)				
Front left	180-1.8 (2.5 boost)	180-1.8 (2.5 boost)	180-1.8 (2.5 boost)	180-1.8 (2.5 boost)
Rear left	145-1.4 (1.8 boost)	180-1.8 (2.5 boost)	180-1.8 (2.5 boost)	145-1.4 (1.8 boost)
Front right	145-1.4 (1.8 boost)	145-1.4 (1.8 boost)	210-2.2 (3.2 boost)	280-2.4 (3.6 boost)
Rear right	180-1.8 (2.5 boost)	210-2.2 (3.2 boost)	-	-
Center	-	-	-	-
<b>FEATURES</b>				
On/off indicator	•	•	•	•
Residual heat indicator	•	•	•	•
Digital display	•	•	•	•
Timer	•	•	•	•
Booster	•	•	•	•
Childlock	•	•	•	•
After overflow safety	•	•	•	•
Automatic shut-off	•	•	•	•
<b>ENERGY CONNECTIONS</b>				
Rated power (kW)	6.4	7.2	6.8	6.8
Voltage (V)	220-240	220-240	220-240	220-240
Frequency (Hz)	50	50	50	50
Rated current (A)	32	32	32	32
<b>DIMENSIONS</b>				
Niche dimensions (WxD) mm	560x490	560x490	560x490	560x490
Product dimensions (HxWxD) mm	55x580x510	55x580x510	55x580x510	55x580x510
Gross weight (kg)	14.4	14.2	14.2	14.3
Net weight (kg)	13.4	12.3	13.3	12.4

HII 64401 T | HII 64400 T | HII 64301 T | HII 64300 T

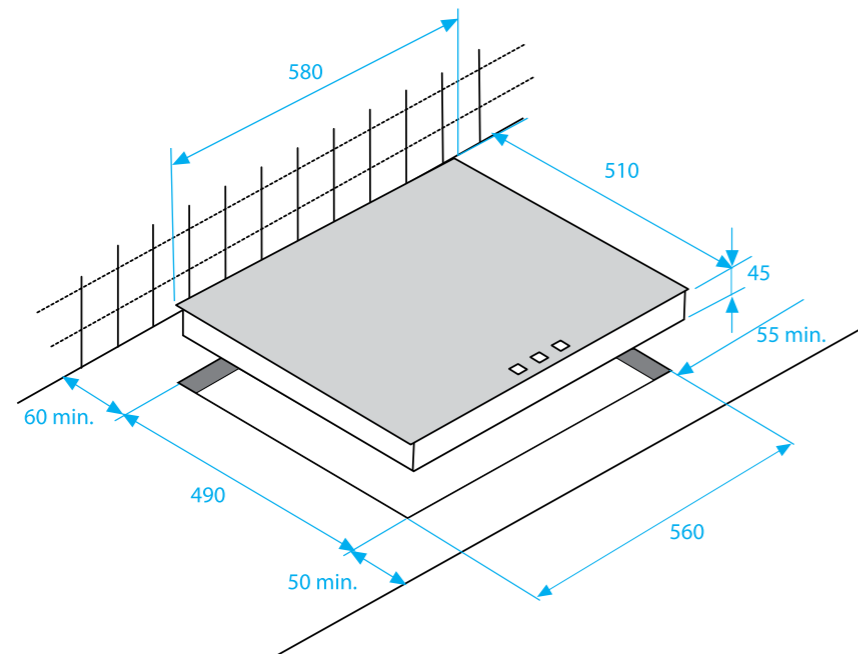

## Electric Hobs



MODEL CODE	HIC 85402 T	HIC 85401 T	HIC 85400 T	HIC 84402 T
<b>TYPE</b>				
Hob type	Vitroc ceramic	Vitroc ceramic	Vitroc ceramic	Vitroc ceramic
Width	80 cm	80 cm	80 cm	80 cm
Frame	-	-	-	-
Color options/frame options				
Stainless steel-X	-	-	•	-
White-W	-	-	-	-
Black-B	-	-	-	-
<b>CONTROL</b>				
Control type	Touch control	Touch control	Touch Control	Touch control
Control knobs placement	Front	Front	Front	Front
Control level per zone	9 cooking positions	9 cooking positions	9 cooking positions	9 cooking positions
<b>ZONES</b>				
Number of zones & type	5 Vitroc ceramic	5 Vitroc ceramic	5 Vitroc ceramic	4 Vitroc ceramic
Zone size (mm) & power (kW)				
Front left	120/210-0.6/2	120/210-0.6/2	120/210-0.6/2	145/200/350-0.9/1.75/2.1
Rear left	160-1.5	140-1.2	160-1.5	-
Front right	140-1.2	160-1.5	140-1.2	140-1.2
Rear right	WP-100W	WP-100W	170/265-1.5/2,4	120/210-0.6/2
Center	140/250-1.1/2	180/230-1.5/2.4	WP-100W	WP-100W
<b>FEATURES</b>				
On/off indicator	•	•	•	•
Residual heat indicator	•	•	•	•
Digital display	•	•	•	•
Timer	•	•	•	•
Booster	•	•	•	•
Childlock	•	•	•	•
After overflow safety	•	•	•	•
Automatic shut-off	•	•	•	•
<b>ENERGY CONNECTIONS</b>				
Rated power (kW)	6.8	7.2	7.1	5.4
Voltage (V)	230	230	230	230
Frequency (Hz)	50	50	50	50
Rated current (A)	32	32	32	32
<b>DIMENSIONS</b>				
Niche dimensions (WxD) mm	750x490	750x490	750x490	750x490
Product dimensions (HxWxD) mm	55x770x510	55x770x510	55x770x510	55x770x510
Gross weight (kg)	12	12	12	12
Net weight (kg)	11	11	11	11

HIC 85402 T | HIC 85401 T | HIC 85400 T | HIC 84402 T

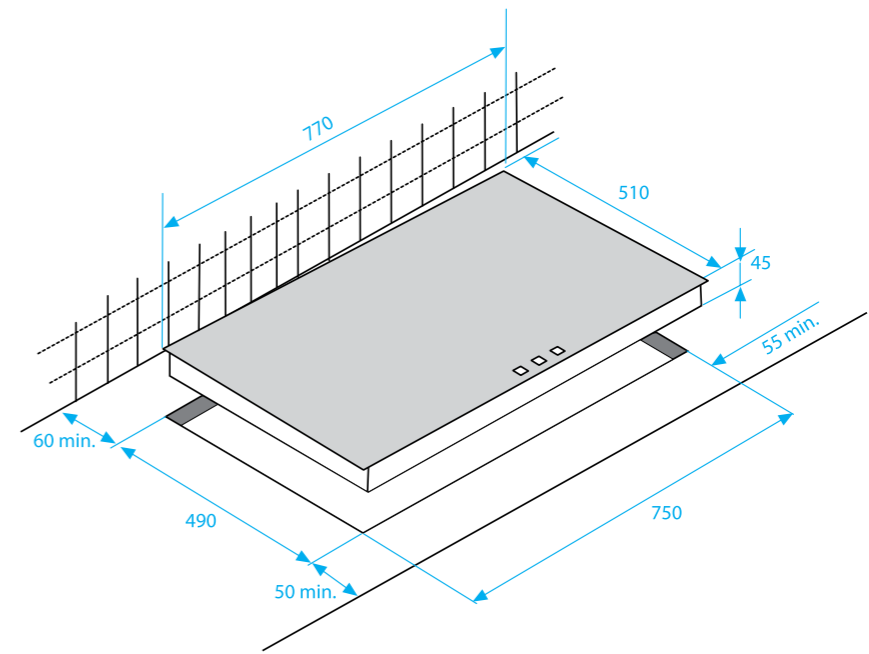

## Electric Hobs



MODEL CODE	HIC 84401 T	HIC 84400 T	HIC 64404 T	HIC 64403 T
<b>TYPE</b>				
Hob type	Vitroc ceramic	Vitroc ceramic	Vitroc ceramic	Vitroc ceramic
Width	80 cm	80 cm	60 cm	60 cm
Frame	-	-	-	-
Color options/frame options				
Stainless steel-X	-	-	-	-
White-W	-	-	-	-
Black-B	-	-	-	-
<b>CONTROL</b>				
Control type	Touch control	Touch Control	Touch control	Touch control
Control knobs placement	Front	Front	Front	Front
Control level per zone	9 cooking positions	9 cooking positions	9 cooking positions	9 cooking positions
<b>ZONES</b>				
Number of zones & type	4 Vitroc ceramic	4 Vitroc ceramic	4 Vitroc ceramic	4 Vitroc ceramic
Zone size (mm) & power (kW)				
Front left	120/180/230-0.8/1.6/2.5	120/210-0.6/2	120/175/210-0.8/1.6/2.3	120/210-0.75/2.2
Rear left	140-1.2	140-1.2	140-1.2	140-1.2
Front right	160-1.5	180-1.8	160-1.5	160-1.5
Rear right	140/250-1.1/2	170/265-1.5/2,4	140/250-1.1/2	140/250-1.1/2
Center	-	-	-	-
<b>FEATURES</b>				
On/off indicator	•	•	•	•
Residual heat indicator	•	•	•	•
Digital display	•	•	•	•
Timer	•	•	•	•
Booster	•	•	•	•
Childlock	•	•	•	•
After overflow safety	•	•	•	•
Automatic shut-off	•	•	•	•
<b>ENERGY CONNECTIONS</b>				
Rated power (kW)	7.2	7.4	7.0	6.9
Voltage (V)	230	230	230	230
Frequency (Hz)	50	50	50	50
Rated current (A)	32	40	32	32
<b>DIMENSIONS</b>				
Niche dimensions (WxD) mm	750x490	750x490	560x490	560x490
Product dimensions (HxWxD) mm	55x770x510	55x770x510	55x580x510	55x580x510
Gross weight (kg)	11.6	12	9	9
Net weight (kg)	10.6	11	8	8

HIC 84401 T | HIC 84400 T

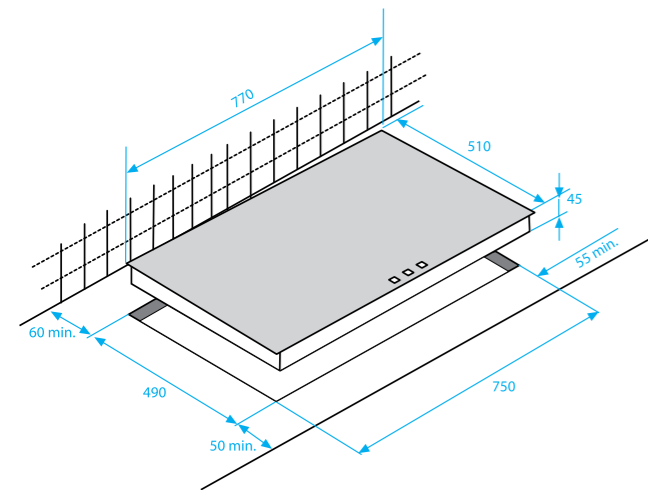

HIC 64404 T | HIC 64403 T

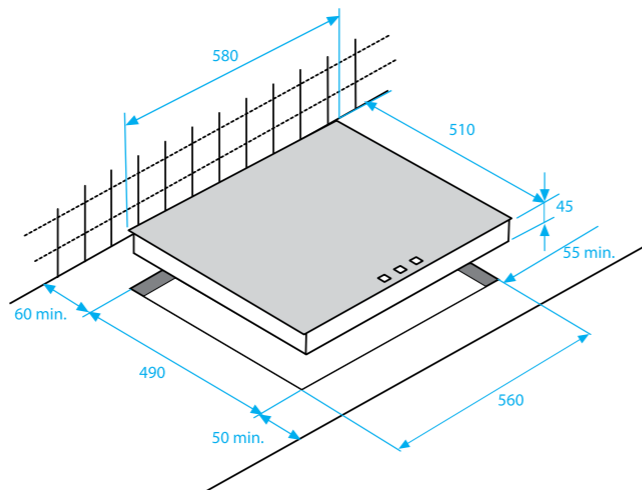

## Electric Hobs

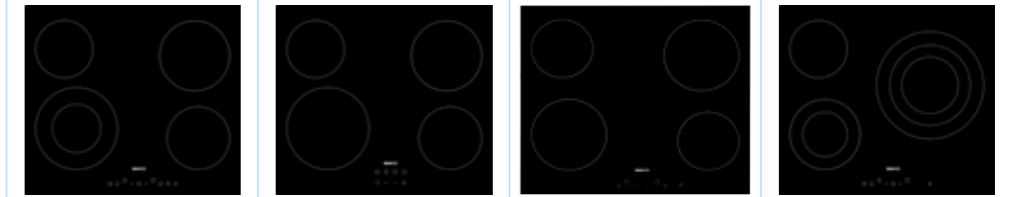

MODEL CODE	HIC 64402 T	HIC 64401 T	HIC 64400	HIC 63402 T
<b>TYPE</b>				
Hob type	Vitroc ceramic	Vitroc ceramic	Vitroc ceramic	Vitroc ceramic
Width	60 cm	60 cm	60 cm	60 cm
Frame	-	-	-	-
Color options/frame options				
Stainless steel-X	-	-	•	-
White-W	-	-	-	-
Black-B	-	-	-	-
<b>CONTROL</b>				
Control type	Touch control	Touch control	Touch Control	Touch control
Control knobs placement	Front	Front	Front	Front
Control level per zone	9 cooking positions	9 cooking positions	9 cooking positions	9 cooking positions
<b>ZONES</b>				
Number of zones & type	4 Vitroc ceramic	4 Vitroc ceramic	4 Vitroc ceramic	3 Vitroc ceramic
Zone size (mm) & power (kW)				
Front left	120/210-0.75/2.2	210-2.3	180-1.8	120/180-0.7/1.7
Rear left	140-1.2	140-1.2	140-1.2	140-1.2
Front right	160-1.5	160-1.5	140-1.2	145/210/275-1/2.2/2.7
Rear right	180-1.8	180-1.8	180-1.8	-
Center	-	-	-	-
<b>FEATURES</b>				
On/off indicator	•	•	•	•
Residual heat indicator	•	•	•	•
Digital display	•	•	•	•
Timer	•	•	-	•
Booster	•	•	•	•
Childlock	•	•	•	•
After overflow safety	•	•	•	•
Automatic shut-off	•	•	•	•
<b>ENERGY CONNECTIONS</b>				
Rated power (kW)	6.7	6.8	6.0	5.6
Voltage (V)	230	230	230	230
Frequency (Hz)	50	50	50	50
Rated current (A)	32	32	32	32
<b>DIMENSIONS</b>				
Niche dimensions (WxD) mm	560x490	560x490	560x490	560x490
Product dimensions (HxWxD) mm	55x580x510	55x580x510	55x580x510	55x580x510
Gross weight (kg)	9	9	9	9
Net weight (kg)	8	8	8	8

HIC 64402 T | HIC 64401 T | HIC 64400 | HIC 63402 T

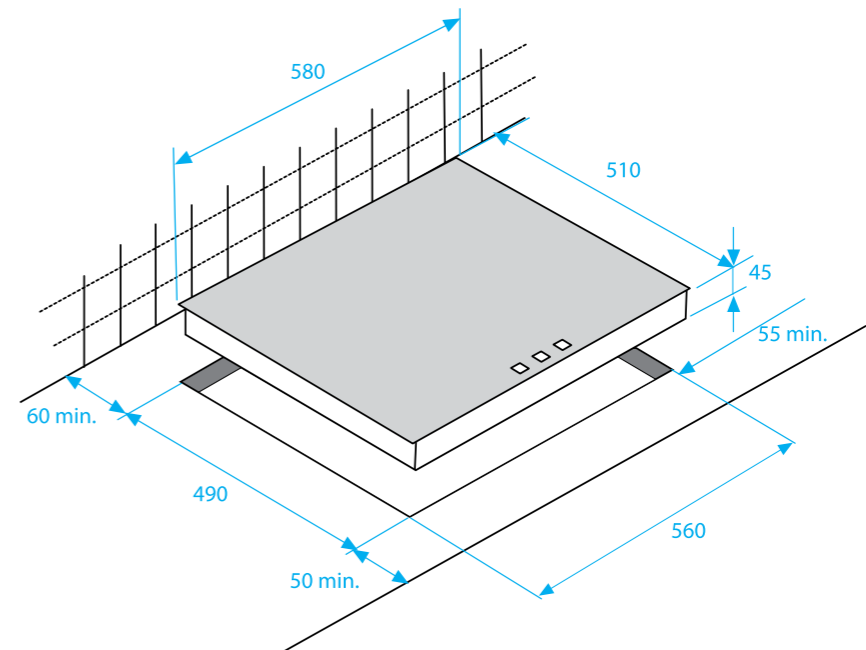

## Electric Hobs



MODEL CODE	HIC 64402 E	HIC 64401 E	HIC 64400 E	HIC 64104
<b>TYPE</b>				
Hob type	Vitroc ceramic	Vitroc ceramic	Vitroc ceramic	Vitroc ceramic
Width	60 cm	60 cm	60 cm	60 cm
Frame	-	-	-	-
Color options/frame options				
Stainless steel-X	-	-	-	-
White-W	-	-	-	-
Black-B	-	-	-	-
<b>CONTROL</b>				
Control type	Touch control	Touch control	Touch control	Mechanical
Control knobs placement	Front	Front	Front	Side
Control level per zone	9 cooking positions	9 cooking positions	9 cooking positions	6 cooking positions
<b>ZONES</b>				
Number of zones & type	4 Vitroc ceramic	4 Vitroc ceramic	4 Vitroc ceramic	4 Vitroc ceramic
Zone size (mm) & power (kW)				
Front left	120/210-0.75/2.2	210-2.3	180-1.8	120/210-0.75/2.2
Rear left	140-1.2	140-1.2	140-1.2	140-1.2
Front right	160-1.5	160-1.5	140-1.2	140-1.2
Rear right	180-1.8	180-1.8	180-1.8	120/180-0.7/1.7
Center	-	-	-	-
<b>FEATURES</b>				
On/off indicator	•	•	•	•
Residual heat indicator	•	•	•	•
Digital display	•	•	•	-
Timer	-	-	-	-
Booster	•	•	•	-
Childlock	•	•	•	-
After overflow safety	•	•	•	-
Automatic shut-off	•	•	•	-
<b>ENERGY CONNECTIONS</b>				
Rated power (kW)	6.7	6.8	6	6.3
Voltage (V)	230	230	230	230
Frequency (Hz)	50	50	50	50
Rated current (A)	32	32	32	32
<b>DIMENSIONS</b>				
Niche dimensions (WxD) mm	560x490	560x490	560x490	560x490
Product dimensions (HxWxD) mm	55x580x510	55x580x510	55x580x510	98x580x510
Gross weight (kg)	9	9	9	9.5
Net weight (kg)	8	8	8	8.5

HIC 64402 E | HIC 64401 E | HIC 64400 E

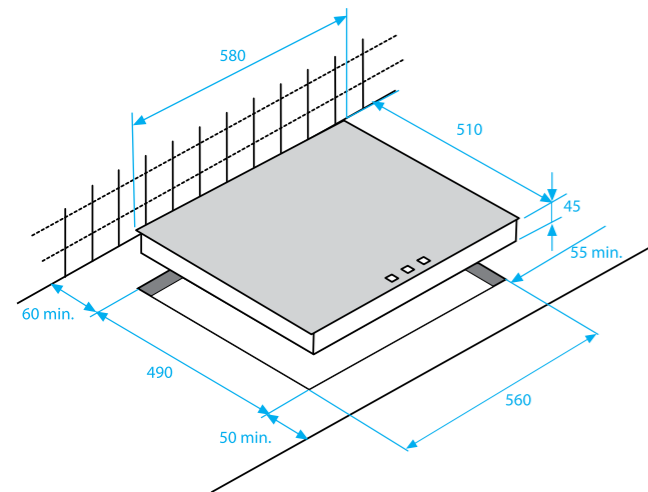

HIC 64104

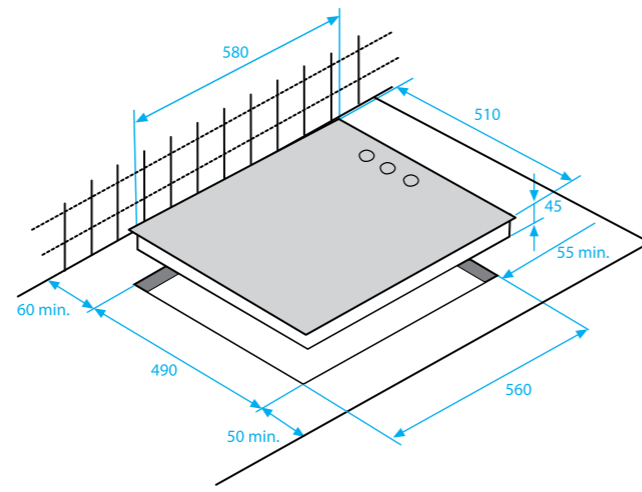

## Electric Hobs



MODEL CODE	HIC 64103	HIC 64102	HIC 64101	HIC 64100
<b>TYPE</b>				
Hob type	Vitroc ceramic	Vitroc ceramic	Vitroc ceramic	•
Width	60 cm	60 cm	60 cm	•
Frame	-	-	-	-
Color options/frame options				
Stainless steel-X	-	-	•	•
White-W	-	-	-	-
Black-B	-	-	-	-
<b>CONTROL</b>				
Control type	Mechanical	Mechanical	Mechanical	Mechanical
Control knobs placement	Side	Side	Side	Side
Control level per zone	6 cooking positions	6 cooking positions	6 cooking positions	6 cooking positions
<b>ZONES</b>				
Number of zones & type	4 Vitroc ceramic	4 Vitroc ceramic	4 Vitroc ceramic	4 Vitroc ceramic
Zone size (mm) & power (kW)				
Front left	210-2.1	210-2.1	120/180-0.7/1.7	180-1.7
Rear left	140-1.2	140-1.2	140-1.2	140-1.2
Front right	140-1.2	140-1.2	140-1.2	140-1.2
Rear right	180-1.8	180-1.7	180-1.7	180-1.7
Center	-	-	-	-
<b>FEATURES</b>				
On/off indicator	•	•	•	•
Residual heat indicator	•	•	•	•
Digital display	-	-	-	-
Timer	-	-	-	-
Booster	-	-	-	-
Childlock	-	-	-	-
After overflow safety	-	-	-	-
Automatic shut-off	-	-	-	-
<b>ENERGY CONNECTIONS</b>				
Rated power (kW)	6.3	6.2	5.8	5.8
Voltage (V)	230	230	230	230
Frequency (Hz)	50	50	50	50
Rated current (A)	32	32	32	32
<b>DIMENSIONS</b>				
Niche dimensions (WxD) mm	560x490	560x490	560x490	560x490
Product dimensions (HxWxD) mm	98x580x510	98x580x510	98x580x510	98x580x510
Gross weight (kg)	9.5	9.5	9.6	9.6
Net weight (kg)	8.5	8.5	8	8

HIC 64103 | HIC 64102

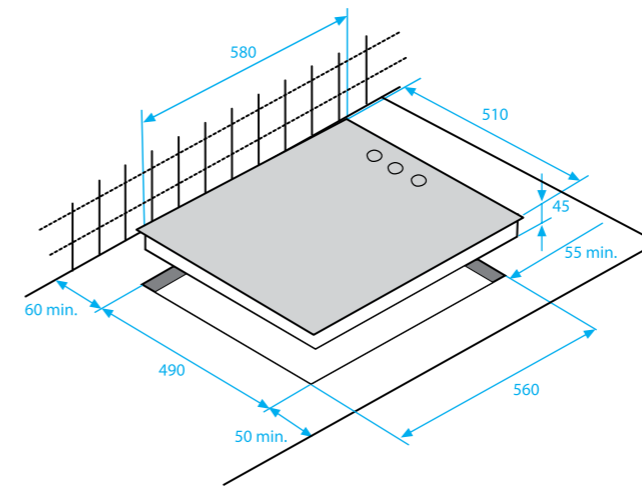

HIC 64101 | HIC 64100

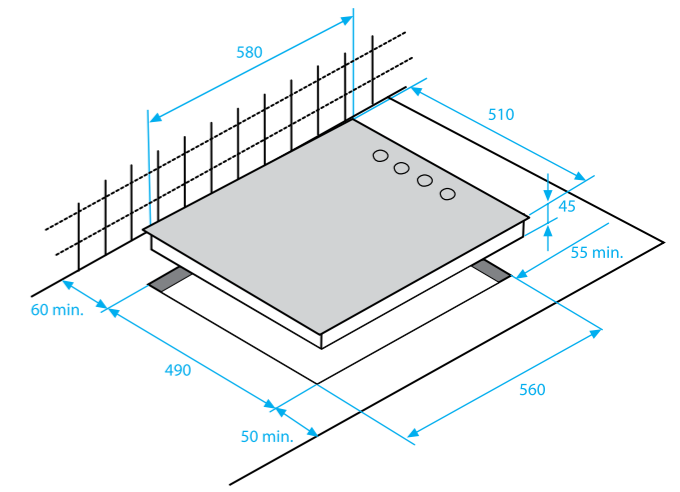

## Electric Hobs



MODEL CODE	HIZE 64101 X/W/B
<b>TYPE</b>	
Hob type	Metal
Width	60 cm
Frame	-
Color options/frame options	
Stainless steel-X	•
White-W	•
Black-B	•
<b>CONTROL</b>	
Control type	Mechanical
Control knobs placement	Side
Control level per zone	6 cooking positions
<b>ZONES</b>	
Number of zones & type	4 hotplates
Zone size (mm) & power (kW)	
Front left	180-1.5
Rear left	145-1
Front right	145-1.5
Rear right	180-2
Center	-
<b>FEATURES</b>	
On/off indicator	•
Residual heat indicator	-
Digital display	-
Timer	-
Booster	-
Childlock	-
After overflow safety	-
Automatic shut-off	-
<b>ENERGY CONNECTIONS</b>	
Rated power (kW)	6
Voltage (V)	220-240
Frequency (Hz)	50
Rated current (A)	32
<b>DIMENSIONS</b>	
Niche dimensions (WxD) mm	560x490
Product dimensions (HxWxD) mm	40x580x490
Gross weight (kg)	10.6
Net weight (kg)	9

HIZE 64101 X/W/B

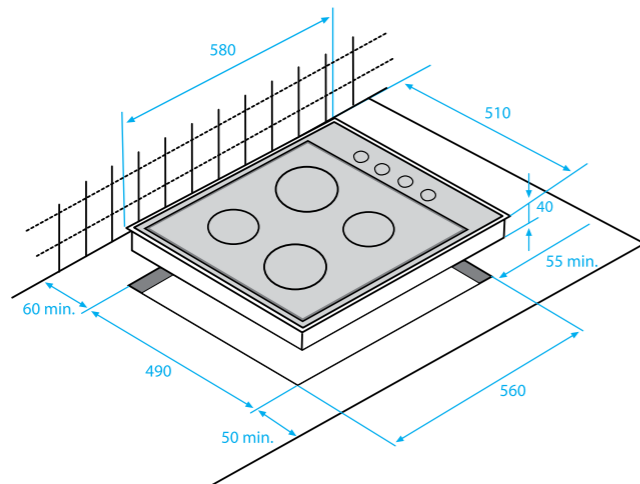

## Gas Hobs

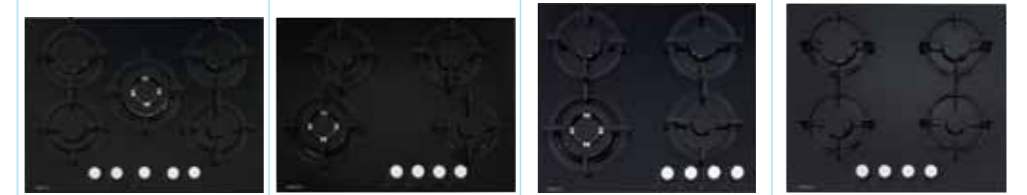

MODEL CODE	HIS 75220 S	HIS 74220 S	HIS 64221 S	HIS 64220 S
<b>TYPE</b>				
Hob type	Glass	Glass	Glass	Glass
Width	70 cm	70 cm	60 cm	60 cm
Frame	-	-	-	-
Color options/frame options				
Stainless Steel-X	-	-	-	-
White-W	-	-	-	•
Silver-S	-	-	-	•
Black-B	•	•	•	•
Charcoal Rustic-CR	-	-	-	-
White Rustic-WR	-	-	-	-
<b>CONTROL</b>				
Control type	Mechanical	Mechanical	Mechanical	Mechanical
Control knobs placement	Front	Front	Front	Front
<b>ZONES</b>				
Number of zones & type	5 gas	4 gas	4 gas	4 gas
Zone Power (kW)				
Front left	2.0	3.6-(wok)	3.6-(wok)	2.0
Rear left	2.9	2.0	2.0	2.9
Front right	1.0	1.0	1.0	1.0
Rear right	2.0	2.0	2.0	2.0
Central	3.6-(wok)	-	-	-
<b>FEATURES</b>				
Burner caps	Cast iron (enamelled optional)	Cast iron (enamelled optional)	Cast iron (enamelled optional)	Enameled (cast iron optional)
Pan supports	Cast iron (enamelled optional)	Cast iron (enamelled optional)	Cast iron (enamelled optional)	Enameled (cast iron optional)
Flame failure device	•	•	•	•
Knob integrated electronic ignition	•	•	•	•
Electronic ignition button	-	-	-	-
<b>ENERGY CONNECTIONS</b>				
Gas type*	G20/G30	G20/G30	G20/G30	G20/G30
Gas pressure* (Mbar)	10-13-20(G20)/30(G30)	20(G20)/30(G30)	20(G20)/30(G30)	10-13-20(G20)/30(G30)
Rated Power (kW)	11.5 kW gas	8.6 kW gas	8.6 kW gas	7.9 kW gas
Voltage (V)	220-230	220-230	220-230	220-230
Frequency (Hz)	50	50	50	50
Rated current (A)				
<b>DIMENSIONS</b>				
Niche dimensions (wxd) mm	560x490	560x490	560x490	560x490
Product dimensions (hxwxd) mm	98x680x510	98x680x510	98x590x510	98x590x510
Gross weight (kg)	17	15.9	12.5	12.5
Net weight (kg)	15	13.7	10.9	10.5

HIS 75220 S

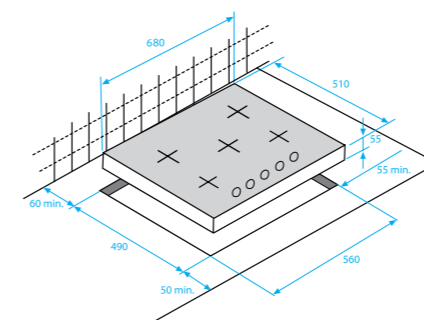

HIS 64221 S | HIS 64220 S

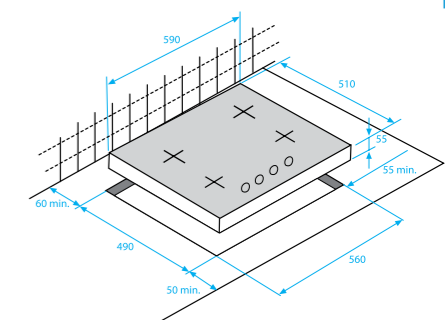

HIS 74220 S

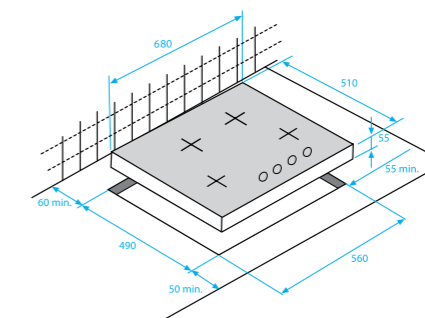

## Gas Hobs



MODEL CODE	HIS 64121 S	HIS 64120	HIG 95222 SX	HIG 75222 SX
<b>TYPE</b>				
Hob type	Glass	Glass	Metal	Metal
Width	60 cm	60 cm	90 cm	75 cm
Frame	-	-	-	-
Color options/frame options				
Stainless Steel-X	-	-	-	-
White-W	•	•	-	-
Silver-S	•	•	-	-
Black-B	•	•	-	-
Charcoal Rustic-CR	-	-	-	-
White Rustic-WR	-	-	-	-
<b>CONTROL</b>				
Control type	Mechanical	Mechanical	Mechanical	Mechanical
Control knobs placement	Side	Side	Front	Front
<b>ZONES</b>				
Number of zones & type	4 Gas	4 gas	4 gas+1 wok	4 gas+1 wok
Zone Power (kW)				
Front left	3,6	2,9	1	1
Rear left	2	2,0	3	3
Front right	1	1,0	1,75	1,75
Rear right	2	2,0	1,75	1,75
Central	-	-	3,8(Wok)	3,8(Wok)
<b>FEATURES</b>				
Burner caps	Enamelled*	Enameled (cast iron optional)	Cast iron	Cast iron
Pan supports	Enamelled*	Enameled (cast iron optional)	Cast iron	Cast iron
Flame failure device	•	-	•	•
Knob integrated electronic ignition	•	•	•	•
Electronic ignition button	-	-	-	-
<b>ENERGY CONNECTIONS</b>				
Gas type*	G20/G30	G20/G30	G 20 on the product G30 as kit	G 20 on the product G30 as kit
Gas pressure* (Mbar)	10-13-20(G20)/30(G30)	10-13-20(G20)/30(G30)		
Rated Power (kW)	7,9 kW gas	7,9 kW gas	11300	11300
Voltage (V)	230	220-230	230 V	230 V
Frequency (Hz)	50	50	50	50
Rated current (A)				
<b>DIMENSIONS</b>				
Niche dimensions (wxd) mm	560x490	560x490	910*580	800*580
Product dimensions (hxwxd) mm	98x590x510	98x590x510	33x860x500	33x740x500
Gross weight (kg)	11,6	11,6	16,4	14,9
Net weight (kg)	9,8	9,8	13,8	12,5

HIS 64121 S | HIS 64120

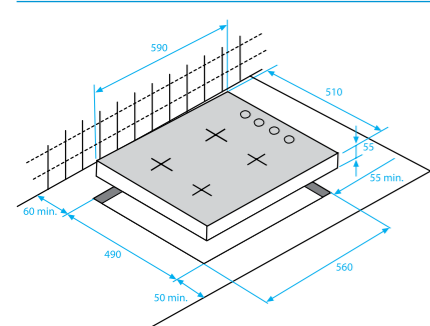

HIG 95222 SX

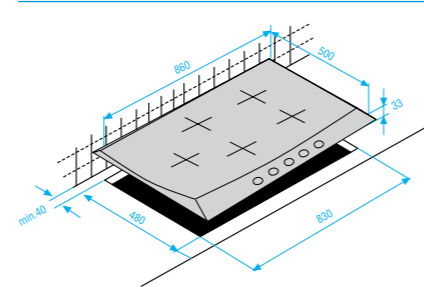

HIG 75222 SX

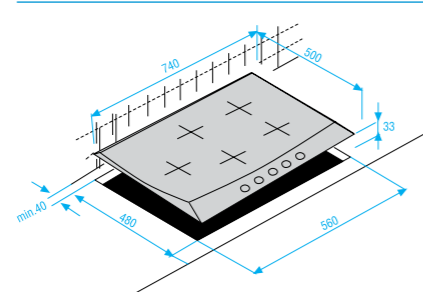

## Gas Hobs

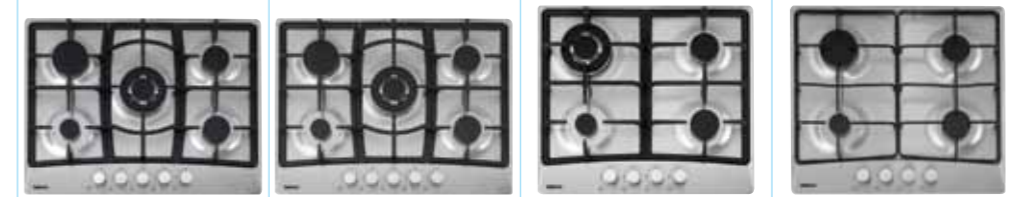

MODEL CODE	HIG 75221 SX	HIG 75220 SX	HIG 64221 SX	HIG 64220 SX
<b>TYPE</b>				
Hob type	Metal	Metal	Metal	Metal
Width	70	70 cm	60 cm	60 cm
Frame	-	-	-	-
Color options/frame options				
Stainless Steel-X	•	•	•	•
White-W	-	-	•	•
Silver-S	-	-	-	-
Black-B	-	-	-	-
Charcoal Rustic-CR	-	-	-	-
White Rustic-WR	-	-	-	-
<b>CONTROL</b>				
Control type	Mechanical	Mechanical	Mechanical	Mechanical
Control knobs placement	Front	Front	Front	Front
<b>ZONES</b>				
Number of zones & type	4 Gas+1 Wok	4 gas+wok	3 Gas+1 Wok	4 Gas
Zone Power (kW)				
Front left	1	1,0	1	1
Rear left	2,9	2,9	3,6 (wok)	2,9
Front right	2	2,0	2	2
Rear right	2	2,0	2	2
Central	3,6 (wok)	3,6 (wok)	-	-
<b>FEATURES</b>				
Burner caps	Cast iron	Mat enamelled	Cast iron*	Enamelled
Pan supports	Cast iron	Mat enamelled	Cast iron*	Enamelled
Flame failure device	•	•	•	•
Knob integrated electronic ignition	•	•	•	•
Electronic ignition button	-	-	-	-
<b>ENERGY CONNECTIONS</b>				
Gas type*	G20/G30	G20/G30	G20/G30	G20/G30
Gas pressure* (Mbar)	20(G20)/30(G30)	20(G20)/30(G30)	20(G20)/30(G30)	20(G20)/30(G30)
Rated Power (kW)	11,5 kW gas	11,5 kW gas	8,6 kW gas	7,9 kW gas
Voltage (V)	230	230	230	230
Frequency (Hz)	50	50	50	50
Rated current (A)				
<b>DIMENSIONS</b>				
Niche dimensions (wxd) mm	560x490	560x490	560x490	560x490
Product dimensions (hxwxd) mm	100x680x510	100x680x510	100x580x510	100x580x510
Gross weight (kg)	14	14	12,2	10
Net weight (kg)	12,3	12,5	10,7	8,5

HIG 75221 SX

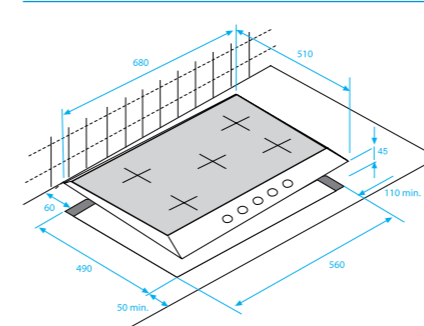

HIG 75220 SX

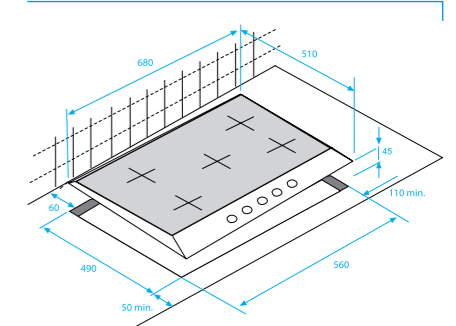

HIG 64221 SX | HIG 64220 SX

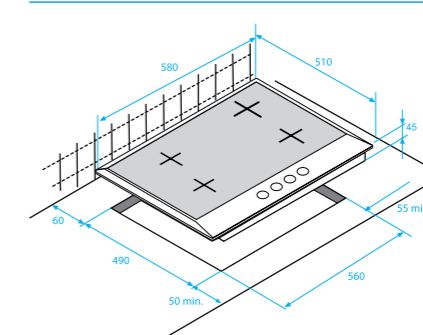

## Gas Hobs



MODEL CODE	HIW 64221 S	HIW 64120 S	HIM 64220 SX	HIM 64120 S
<b>TYPE</b>				
Hob type	Vitroc ceramic	Vitroc ceramic	Metal	Metal
Width	60 cm	60 cm	60 cm	60 cm
Frame	-	-	-	-
Color options/frame options				
Stainless Steel-X	-	-	•	•
White-W	-	-	•	-
Silver-S	•	•	-	-
Black-B	•	•	-	-
Charcoal Rustic-CR	-	-	-	-
White Rustic-WR	-	-	-	-
<b>CONTROL</b>				
Control type	Mechanical front	Mechanical Side	Mechanical Front	Mechanical Side
Control knobs placement	front	Side	Front	Side
<b>ZONES</b>				
Number of zones & type	2 Vitroc ceramic+2 Gas	2 Vitroc ceramic+2 Gas	3 Gas+1 Hotplate	3 gas+1 hotplate
Zone Power (kW)				
Front left	180-1.8	180-1.7	1	3.1
Rear left	140-1.2	140-1.2	145 mm/1,0	145 mm/1,5
Front right	1.0	1.0	2	0.85
Rear right	2.0	2.0	2.9	2.3
Central	-	-	-	-
<b>FEATURES</b>				
Burner caps	Cast iron (enamelled optional)	Enamelled (cast iron optional)	Enamelled	Enamelled
Pan supports	Cast iron (enamelled optional)	Enamelled (cast iron optional)	Enamelled	Enamelled
Flame failure device	•	•	•	-
Knob integrated electronic ignition	•	•	•	•
Electronic ignition button	-	-	-	-
<b>ENERGY CONNECTIONS</b>				
Gas type*	G20/G30	G20/G30	G20/G30	G20
Gas pressure* (Mbar)	20(G20)/30(G30)	13-20(G20)/30(G30)	20(G20)/30(G30)	20
Rated Power (kW)	3 kW gas ; 3 kW electric	3 kW gas ; 2.9 kW electric	5,9 kW Gas/1 kW electric	Gas : 6,25 kW-Elect.: 1,5 kW
Voltage (V)	220-230	220-230	230	220-240
Frequency (Hz)	50	50	50	50
Rated current (A)	16	16		
<b>DIMENSIONS</b>				
Niche dimensions (wxd) mm	560x490	560x490	560x490	560/480
Product dimensions (hxwxd) mm	98x590x510	98x590x510	100x580x510	100/580/510
Gross weight (kg)	10.9	10.5	10.7	11
Net weight (kg)	9.4	8.9	9.2	

HIW 64221 S

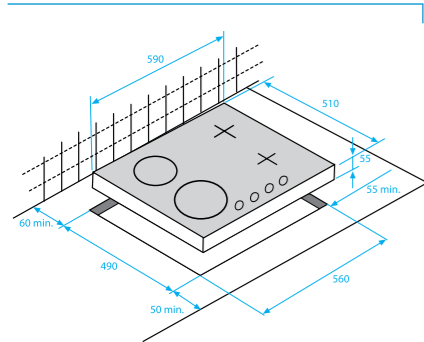

HIW 64120 S

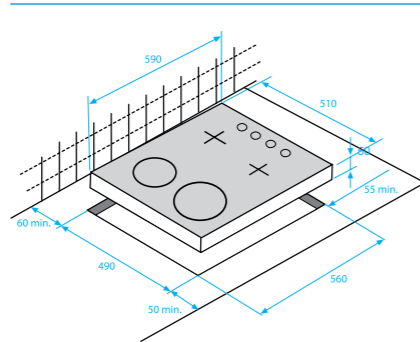

HIM 64220 SX

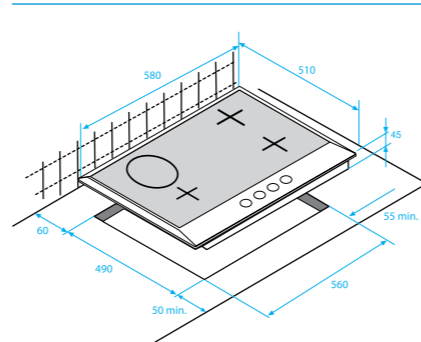

HIM 64120 S

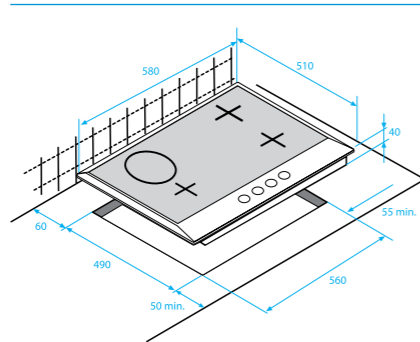

## Gas Hobs



MODEL CODE	HIZG 64121	HIZG 64120	HIZG 64120 R	HIZG 64110
<b>TYPE</b>				
Hob type	Metal	Metal	Metal	Metal
Width	60 cm	60 cm	60 cm	60 cm
Frame	-	-	-	-
Color options/frame options				
Stainless Steel-X	•	•	-	•
White-W	•	•	-	•
Silver-S	•	-	-	-
Black-B	•	•	-	•
Charcoal Rustic-CR	-	-	•	-
White Rustic-WR	-	-	•	-
<b>CONTROL</b>				
Control type	Mechanical Side	Mechanical Side	Mechanical Side	Mechanical Side
Control knobs placement	Side	Side	Side	Side
<b>ZONES</b>				
Number of zones & type	3 gas+1 wok	4 gas	4 gas	4 gas
Zone Power (kW)				
Front left	3.6 (wok)	2.9	2.9	2.9
Rear left	2.0	2.0	2.0	2.0
Front right	1.0	1.0	1.0	1.0
Rear right	2.0	2.0	2.0	2.0
Central	-	-	-	-
<b>FEATURES</b>				
Burner caps	Enamelled (cast iron optional)	Enamelled (cast iron optional)	Enamelled (cast iron optional)	Enamelled
Pan supports	Enamelled (cast iron optional)	Enamelled (cast iron optional)	Enamelled (cast iron optional)	Enamelled
Flame failure device	•	Optional	Optional	-
Knob integrated electronic ignition	•	•	•	-
Electronic ignition button	-	-	-	•
<b>ENERGY CONNECTIONS</b>				
Gas type*	G20/G30	G20/G30	G20/G30	G20/G30
Gas pressure* (Mbar)	20(G20)/30(G30)	10-13-20(G20)/30(G30)	10-13-20(G20)/30(G30)	20(G20)/30(G30)
Rated Power (kW)	8.6 kW gas	7.9 kW gas	7.9 kW gas	7.9 kW gas
Voltage (V)	220-240	220-240	220-240	220-240
Frequency (Hz)	50	50	50	50
Rated current (A)				
<b>DIMENSIONS</b>				
Niche dimensions (wxd) mm	560x490	560x490	560x490	560x490
Product dimensions (hxwxd) mm	87x580x510	87x580x510	87x580x510	87x580x510
Gross weight (kg)	9.6	9.6	9.6	9.6
Net weight (kg)	8.0	8.0	8.0	8.0

HIZG 64121 | HIZG 64120 | HIZG 64120 WR | HIZG 64110

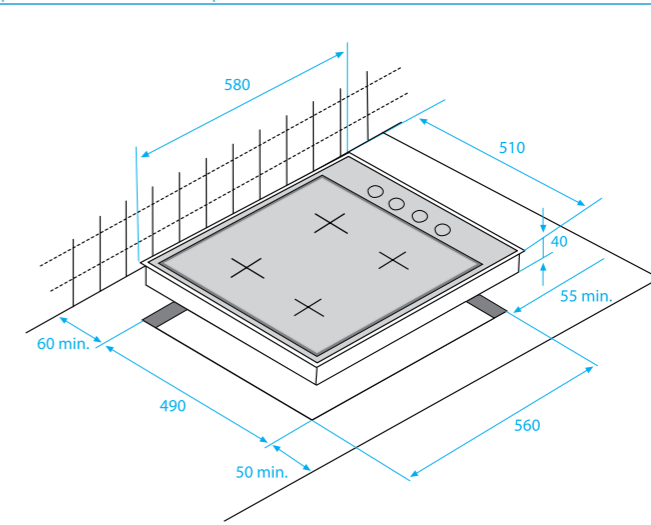



## Gas Hobs



MODEL CODE	HIZG 64100 X	HIZG 63120	HIZM 64121 S	HIZM 64120 S
<b>TYPE</b>				
Hob type	Metal	Metal	Metal	Metal
Width	60 cm	60 cm	60 cm	60 cm
Frame	-	-	-	-
Color options/frame options				
Stainless Steel-X	•	•	•	•
White-W	•	-	•	•
Silver-S	-	-	-	-
Black-B	•	-	-	-
Charcoal Rustic-CR	-	-	-	-
White Rustic-WR	-	-	-	-
<b>CONTROL</b>				
Control type	Mechanical	Mechanical	Mechanical	Mechanical
Control knobs placement	Side	Side	Side	Side
<b>ZONES</b>				
Number of zones & type	4 gas	2 gas+1 wok	2 gas+2 hotplate	3 gas+1 hotplate
Zone Power (kW)				
Front left	2.9	3.6 (wok)	180 mm/2.0	2.9
Rear left	2.0	-	145 mm/1.0	145 mm/1.0
Front right	1.0	1.0	1.0	1.0
Rear right	2.0	2.0	2.0	2.0
Central	-	-	-	-
<b>FEATURES</b>				
Burner caps	Enameled	Cast iron	Enameled	Enameled
Pan supports	Enameled	Cast iron	Enameled	Enameled
Flame failure device	-	-	•	•
Knob integrated electronic ignition	-	•	•	•
Electronic ignition button	-	-	-	-
<b>ENERGY CONNECTIONS</b>				
Gas type*	G20/G30	G20/G30	G20/G30	G20/G30
Gas pressure* (Mbar)	20(G20)/30(G30)	20(G20)/30(G30)	20(G20)/30(G30)	10-13-20(G20)/30(G30)
Rated Power (kW)	7.9 kW gas	6.6 kW gas	3 kW gas ; 3 kW electric	5.9 kW gas ; 1 kW electric
Voltage (V)	220-240	220-240	220-240	220-240
Frequency (Hz)	50	50	50	50
Rated current (A)			16	16
<b>DIMENSIONS</b>				
Niche dimensions (wxd) mm	560x490	560x490	560x490	560x490
Product dimensions (hxwxd) mm	87x580x510	85x580x510	87x580x510	87x580x510
Gross weight (kg)	9.6	10.5	10.2	9.7
Net weight (kg)		9	8.7	8.2

## Gas Hobs



MODEL CODE	HIZM 64110
<b>TYPE</b>	
Hob type	Metal
Width	60 cm
Frame	-
Color options/frame options	
Stainless Steel-X	•
White-W	•
Silver-S	-
Black-B	•
Charcoal Rustic-CR	-
White Rustic-WR	-
<b>CONTROL</b>	
Control type	Mechanical
Control knobs placement	Side
<b>ZONES</b>	
Number of zones & type	3 gas+1 hotplate
Zone Power (kW)	
Front left	2.9
Rear left	145 mm/1.0
Front right	1.0
Rear right	2.0
Central	-
<b>FEATURES</b>	
Burner caps	Enameled
Pan supports	Enameled
Flame failure device	-
Knob integrated electronic ignition	-
Electronic ignition button	•
<b>ENERGY CONNECTIONS</b>	
Gas type*	G20/G30
Gas pressure* (Mbar)	20(G20)/30(G30)
Rated Power (kW)	5.9 kW gas ; 1 kW electric
Voltage (V)	220-240
Frequency (Hz)	50
Rated current (A)	16
<b>DIMENSIONS</b>	
Niche dimensions (wxd) mm	560x490
Product dimensions (hxwxd) mm	87x580x510
Gross weight (kg)	9.7
Net weight (kg)	8.2

HIZG 64100 X

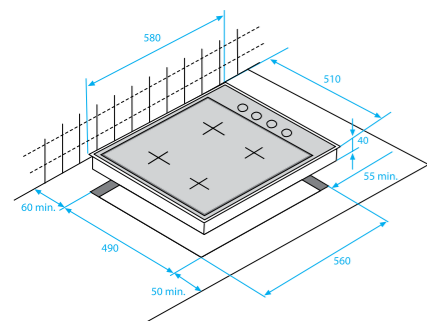

HIZG 63120

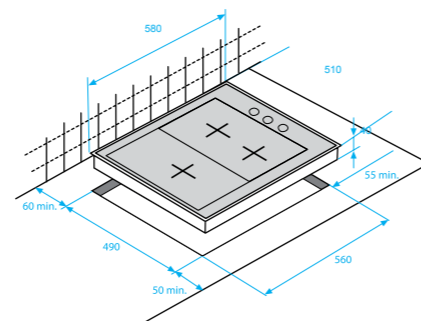

HIZM 64121 S | HIZM 64120 S

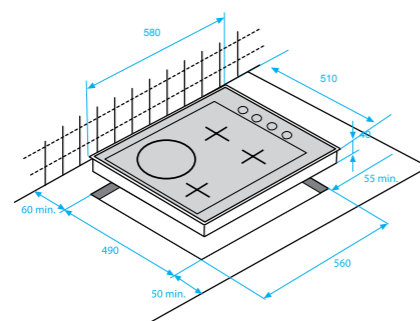

HIZM 64110

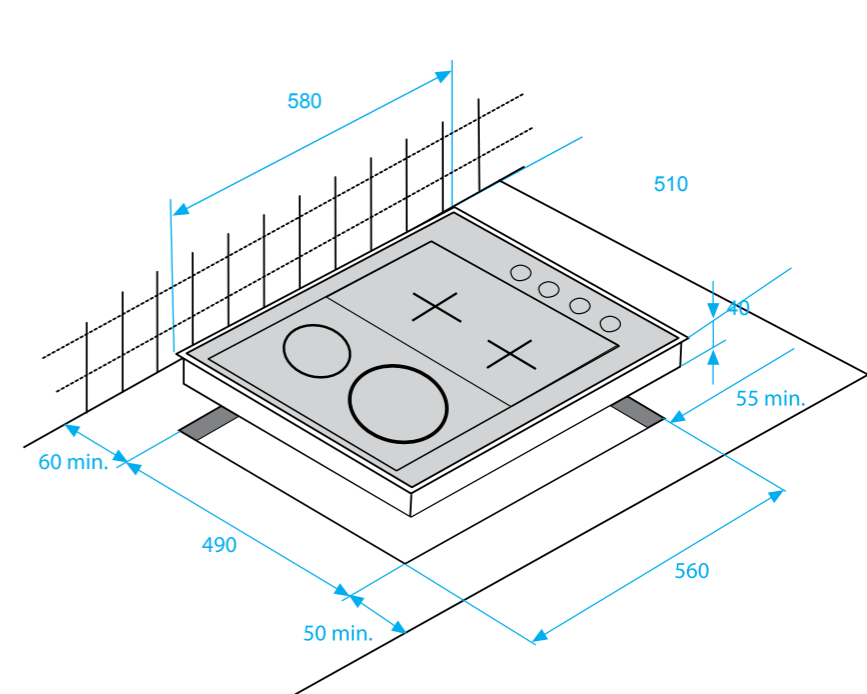

# Domino Hobs



MODEL CODE	HDS 32400 X	HDC 32201 X	HDC 32200 X	HDS 32222 SX
<b>TYPE</b>				
Hob type	Vitroc ceramic	Vitroc ceramic	Vitroc ceramic	Glass
Width	30 cm	30 cm	30 cm	30 cm
Color options	Stainless steel-X White-W	·	·	·
<b>ZONES</b>				
Number of zones & type	2 Vitroc ceramic	2 Vitroc ceramic	2 Vitroc ceramic	1 gas (WOK )
Zone power (kW)	Front 140 mm-1300W Rear 180 mm-1700W	140 mm-1300W 180 mm-1700W	140 mm-1200 W 180 mm-1700 W	3,8 kW -
<b>FEATURES</b>				
On/off indicator	·	·	·	-
Burner caps	-	-	-	Cast Iron
Pan supports	-	-	-	Cast Iron
Knob integrated electronic ignition	-	-	-	·
Electronic ignition button	-	-	-	-
<b>ENERGY CONNECTIONS</b>				
Gas type*	-	-	-	G20/G30
Gas pressure* (Mbar)	-	-	-	20 (G20)/30 (G30)
Rated power (kW)	3.0 kW	3.0 kW	2,9 kW	3,8 kW
Voltage (V)	230	220-240	230	220-240
Frequency (Hz)	50	50	50	50
Maxcurrent intensity (A)	12	12	16 A	3
<b>DIMENSIONS</b>				
Niche dimensions (wxd) mm	270x490	270x490	268x490	270x490
Product dimensions (hxwxd) mm	71x288x510	71x290x510	71x288x510	80x290x510
Gross weight (kg)	4.6	4.6	4.2	5.7
Net weight (kg)	4	4	3.5	5.1
Gas Safety	-	-	-	·

# Domino Hobs



MODEL CODE	HDS 32221 SX	HDS 32220 S	HDE 32201 X	HDE 32200
<b>TYPE</b>				
Hob type	Glass	Glass	Metal	Metal
Width	30 cm	30 cm	30 cm	30 cm
Color options	Stainless steel-X White-W	·	·	·
<b>ZONES</b>				
Number of zones & type	2 gas	2 Gas	2 hotplates	2 Hotplates
Zone power (kW)	Front 1 kW Rear 3 kW	1 kW 2 kW	145 mm-1.5 kW (Rapid) 180 mm-2.0 kW (Rapid)	145 mm-1000 W 180 mm-1500 W
<b>FEATURES</b>				
On/off indicator	-	-	·	·
Burner caps	Cast Iron	Enamelled	-	-
Pan supports	Cast Iron	Enamelled	-	-
Knob integrated electronic ignition	·	·	-	-
Electronic ignition button	-	-	-	-
<b>ENERGY CONNECTIONS</b>				
Gas type*	G20/G30	G20/G30	-	-
Gas pressure* (Mbar)	20 (G20)/30 (G30)	20(G20)/30(G30)	-	-
Rated power (kW)	4 kW	3,9 kW	3.5 kW	2,5 kW
Voltage (V)	220-240	230	220-240	230
Frequency (Hz)	50	50	50	50
Maxcurrent intensity (A)	3	10A	16	16 A
<b>DIMENSIONS</b>				
Niche dimensions (wxd) mm	270x490	268x490	270x490	268x490
Product dimensions (hxwxd) mm	71x290x510	100x288x510	71x290x510	71x288x510
Gross weight (kg)	5.9	5	5.5	5.7
Net weight (kg)	5.3	4.3	4.9	5
Gas Safety	·	·	-	-

HDS 32400 X | HDC 32201 X

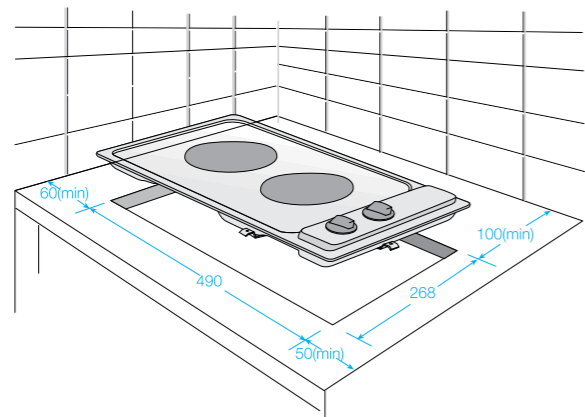

HDS 32221 SX

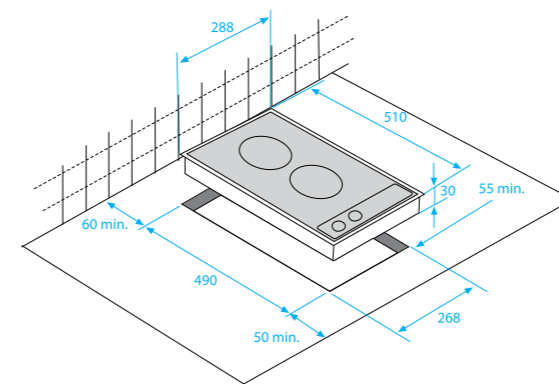

HDS 32220 SX

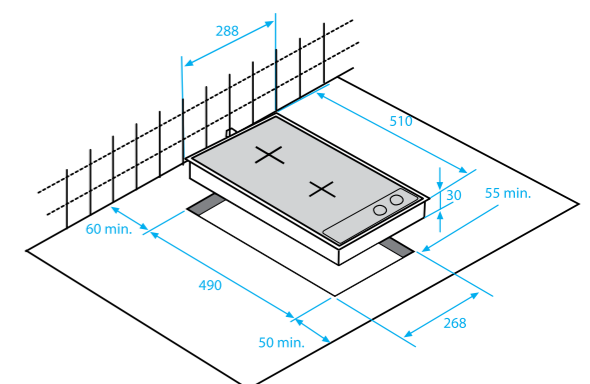

HDC 32200 X

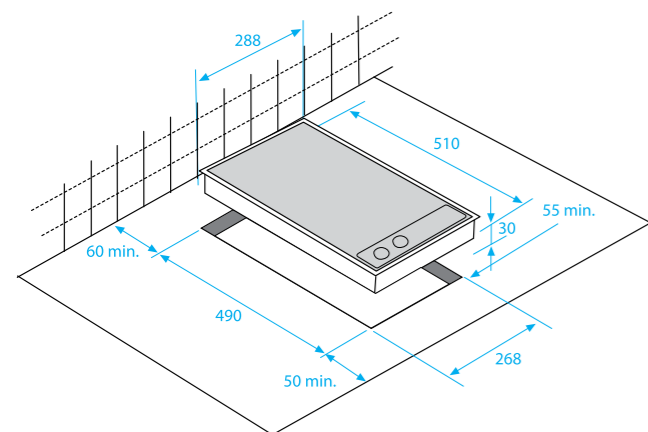

HDS 32222 SX

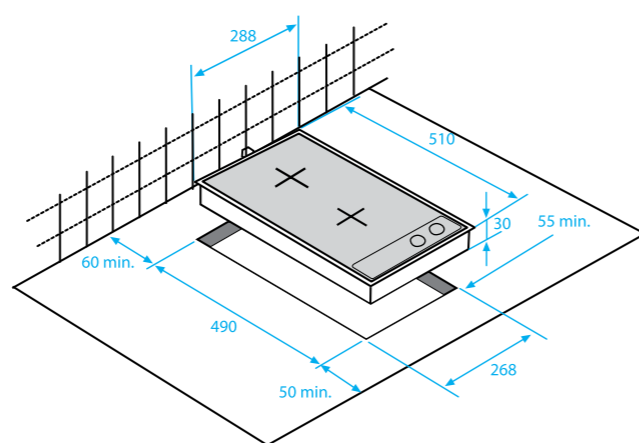

HDE 32201X | HDE 32200 X

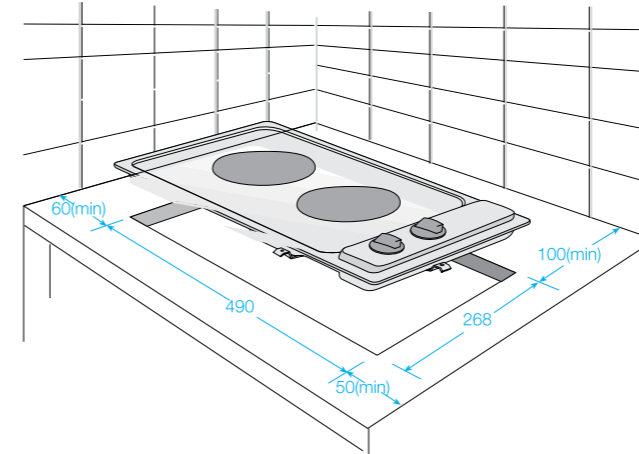

HDE 32200 X

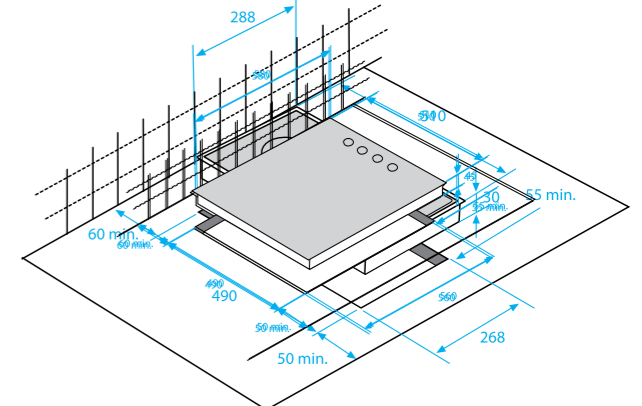

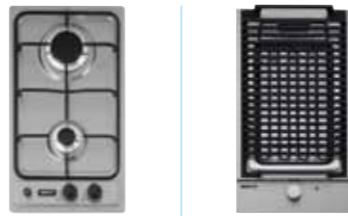

MODEL CODE	HDG 32210 S	HDB 30200
<b>TYPE</b>		
Hob type	Metal	Metal
Width	30 cm	30 cm
Color options	Stainless steel-X White-W	· -
<b>ZONES</b>		
Number of zones & type	2 Gas	Barbecue
Zone power (kW)	Front Rear	
	1 kW 2,9 kW	
<b>FEATURES</b>		
On/off indicator	-	-
Burner caps	Enamelled	Cast Iron
Pan supports	Enamelled	Cast Iron
Knob integrated electronic ignition	-	-
Electronic ignition button	·	-
<b>ENERGY CONNECTIONS</b>		
Gas type*	G20/G30	
Gas pressure* (Mbar)	10-13-20(G20)/30(G30)	
Rated power (kW)	3,9 kW	2,4 kW
Voltage (V)	230	220-240
Frequency (Hz)	50	50
Maxcurrent intensity (A)	10A	16
<b>DIMENSIONS</b>		
Niche dimensions (wxd) mm	268x490	270x490
Product dimensions (hxwxd) mm	80x288x510	80x290x510
Gross weight (kg)	5.1	7.3
Net weight (kg)	4.4	7.9
Gas Safety	·	-

# Cooker Hoods

HDG 32210 SX

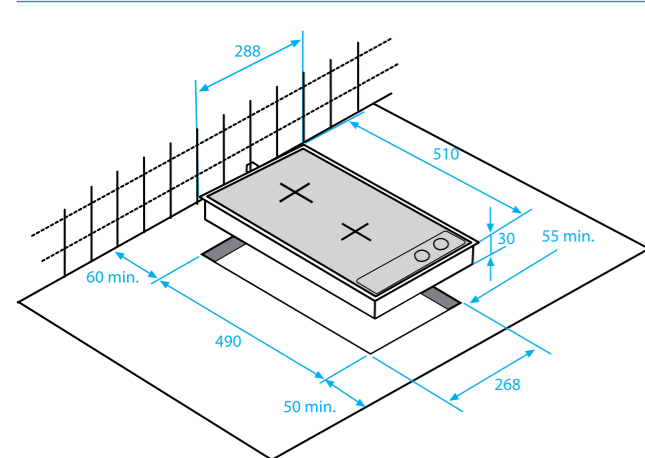

HDB 30200

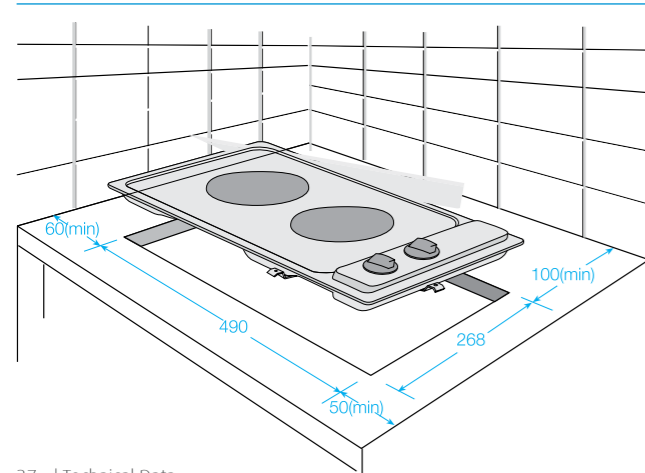

## Cooker Hoods



MODEL CODE	CWB 9910 X	CWB 9900 X	CWB 9710 X	CIB 9600 X
Type	Wall mounted	Wall mounted	Wall mounted	Island
Width category (mm)	900	900	900	900
Colour	Inox	Black	Inox	Inox
<b>FEATURES</b>				
Type of control	Touch Control	Touch Control	Touch Control	Push Button
Number of speeds	4	4	4	3
Number of motors	1	1	1	1
Extraction capacity (m³/h)	755	755	755	755
Number of lights and wattage	3x20 W	2x20 W	2x20 W	4x20 W
Grease filter	2xAluminium cassette	2xAluminium cassette	3xAluminium cassette	3xAluminium cassette
Glass visor	-	-	-	-
<b>ENERGY CONNECTIONS</b>				
Total power (W)	310	290	290	330
Voltage (V)	220-240	220-240	220-240	220-240
Frequency (Hz)	50	50	50	50
Amperage (A)	10	10	10	10
<b>DIMENSIONS</b>				
Height (mm)	466	1020-1490	690-1155	710-1075
Width (mm)	900	900	900	900
Depth (mm)	387	340	480	600
Gross weight (kg)	24	27	24	35.9
Net weight (kg)	17	21	19	29.5

## Cooker Hoods



MODEL CODE	CWB 9600 X	CWB 9510 X	CWB 9500 X	CWB 9441 X/W
Type	Wall mounted	Wall mounted	Wall mounted	Wall mounted
Width category (mm)	900	900	900	900
Colour	Inox	Inox	Inox	Inox/White
<b>FEATURES</b>				
Type of control	Push Button	Push Button	Push Button	Push Button
Number of speeds	3	3	3	3
Number of motors	1	1	1	1
Extraction capacity (m³/h)	530	500	530	500
Number of lights and wattage	2x20 W	2x40 W	2x40 W	2x40 W
Grease filter	2xAluminium cassette	2xAluminium cassette	3xAluminium cassette	3xAluminium cassette
Glass visor	-	-	-	-
<b>ENERGY CONNECTIONS</b>				
Total power (W)	270	230	310	230
Voltage (V)	220-240	220-240	220-240	220-240
Frequency (Hz)	50	50	50	50
Amperage (A)	10	16	10	10
<b>DIMENSIONS</b>				
Height (mm)	663-1128	800-1500	690-1155	740-1140
Width (mm)	900	898	900	898
Depth (mm)	500	490	480	502
Gross weight (kg)	22.1		22.3	17
Net weight (kg)	17.8		17.3	13.5

CWB 9910 X | CWB 9900 X

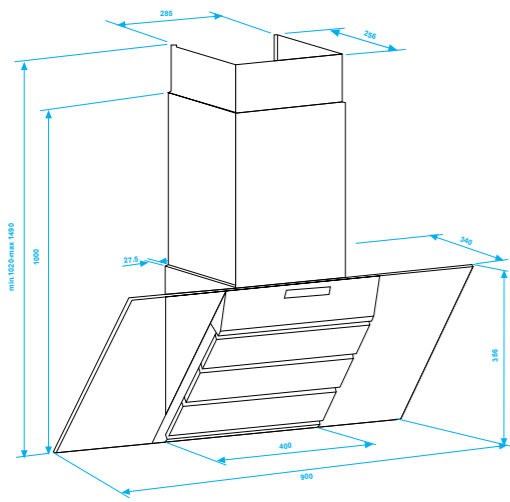

CWB 9710 X

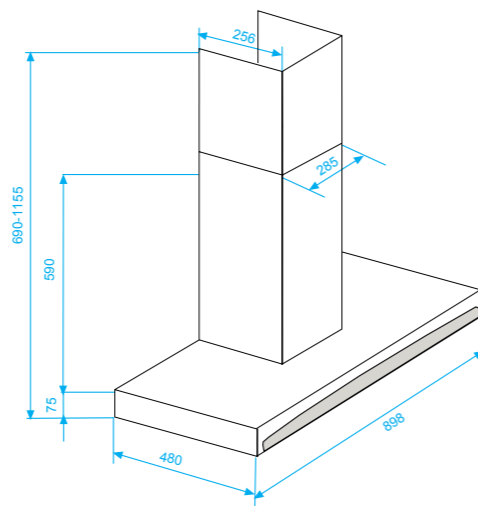

CWB 9600 X

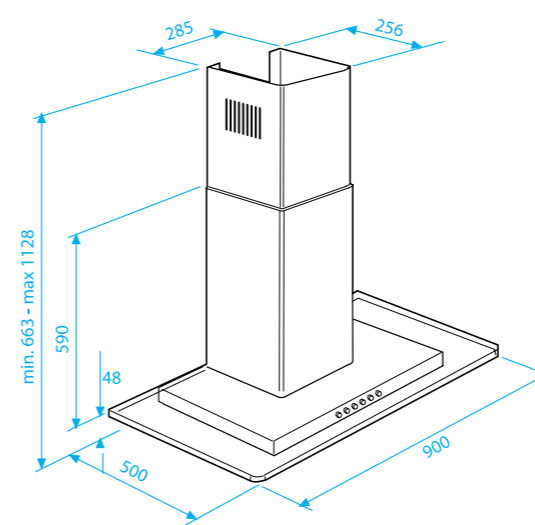

CWB 9510 X

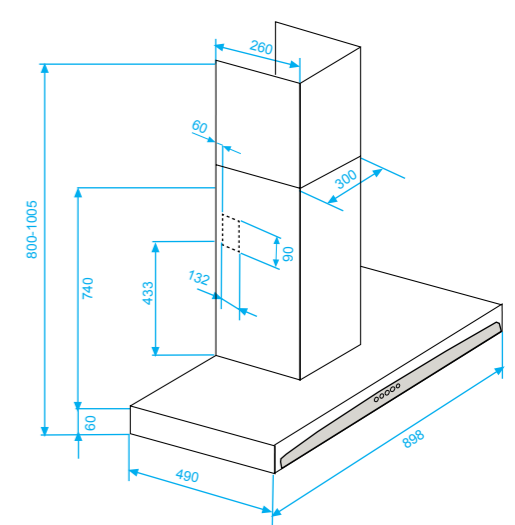

CIB 9600 X

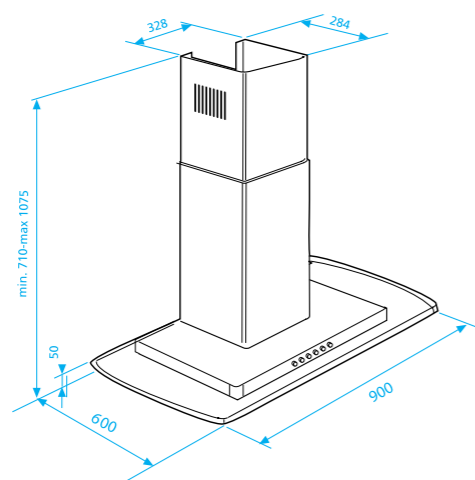

CWB 9500 X

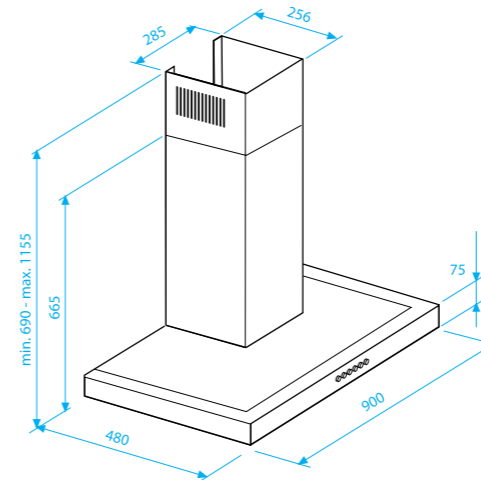

CWB 9441 X/W

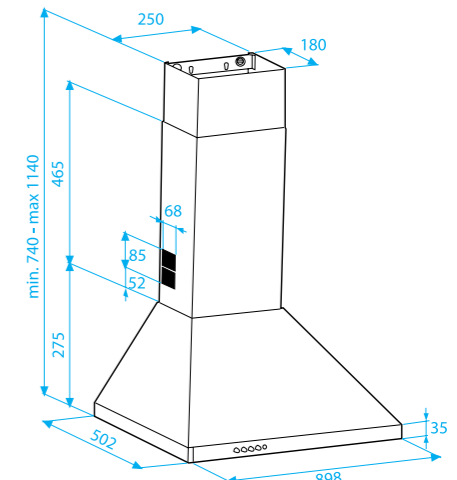

## Cooker Hoods



MODEL CODE	CWB 6510 X	CCB 6486 W	CWB 6441 X/W	CWB 6441 BR/WR
Type	Wall mounted	Canopy	Wall mounted	Wall mounted
Width category (mm)	600	550	600	600
Colour	Inox	White	Inox/White	Black/White
<b>FEATURES</b>				
Type of control	Push Button	Slider switch	Push Button	Push Button
Number of speeds	3	3	3	3
Number of motors	1	2	1	1
Extraction capacity (m³/h)	500	375	500	500
Number of lights and wattage	2x40 W	2x40 W	2x40 W	2x40 W
Grease filter	2xAluminium cassette	1xAluminium cassette	2xAluminium cassette	2xAluminium cassette
Glass visor	-	-	-	-
<b>ENERGY CONNECTIONS</b>				
Total power (W)	230	300	230	230
Voltage (V)	220-240	220-240	220-240	220-240
Frequency (Hz)	50	50	50	50
Amperage (A)	16	10	10	10
<b>DIMENSIONS</b>				
Height (mm)	800-1005	140	740-1140	740-1140
Width (mm)	598	550	598	598
Depth (mm)	490	295	502	502
Gross weight (kg)		8	15	15.5
Net weight (kg)		7.3	11	11.5

CWB 6510 X

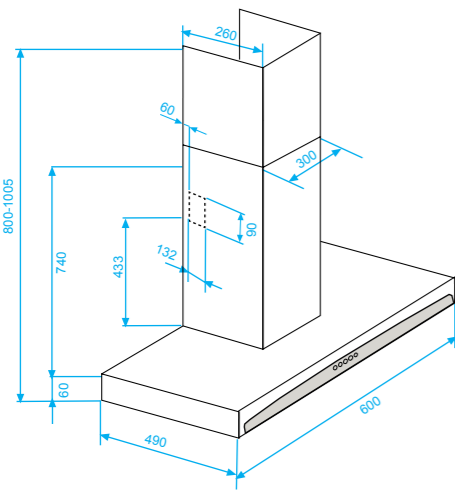

CCB 6486 W

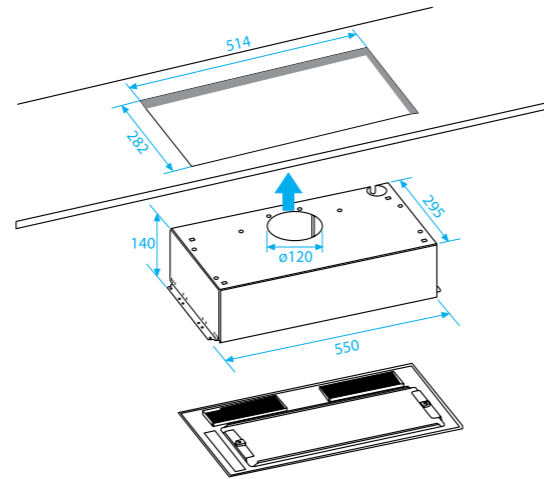

CWB 6441 X/W

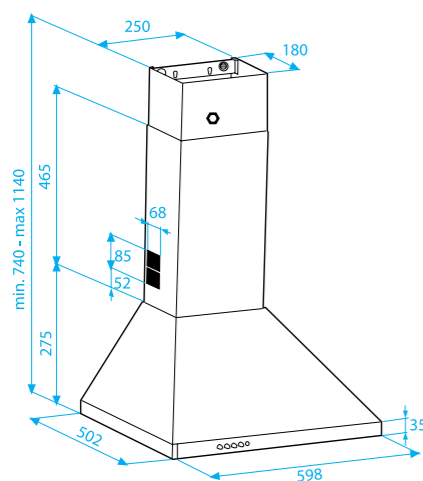

CWB 6441 BR/WR

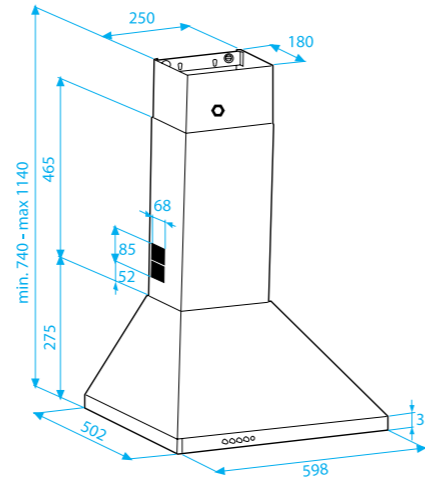

## Cooker Hoods

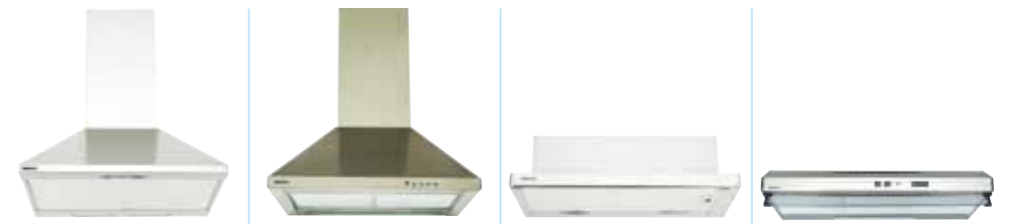

MODEL CODE	CWB 6430 X/W	CWB 6420 X	CTB 6407 X/W	CFB 9433 X
Type	Wall mounted	Wall mounted	Telescopic	Standard
Width category (mm)	600	600	600	900
Colour	Inox/White	INOX	Inox/White	Inox
<b>FEATURES</b>				
Type of control	Slider switch	Push Button	Slider switch	Slider switch
Number of speeds	3	3	3	3
Number of motors	1	1	1	2
Extraction capacity (m³/h)	440	410	375	450
Number of lights and wattage	2x40 W	2x40W	2x40 W	2x40 W
Grease filter	2xAluminium cassette	2xAluminium cassette	2xAluminium cassette	3xAluminium cassette
Glass visor	-	-	-	-
<b>ENERGY CONNECTIONS</b>				
Total power (W)	200	200	220	330
Voltage (V)	220-240	220-240 V	220-240	220-240
Frequency (Hz)	50	50	50	50
Amperage (A)	10	10	10	10
<b>DIMENSIONS</b>				
Height (mm)	750-1095	560-905	175	150
Width (mm)	600	600	598	898
Depth (mm)	492	485	300-452	490
Gross weight (kg)	10.2	6.4	8	10.4
Net weight (kg)	7.7	5.2	8.7	9.2

CWB 6430 X/W

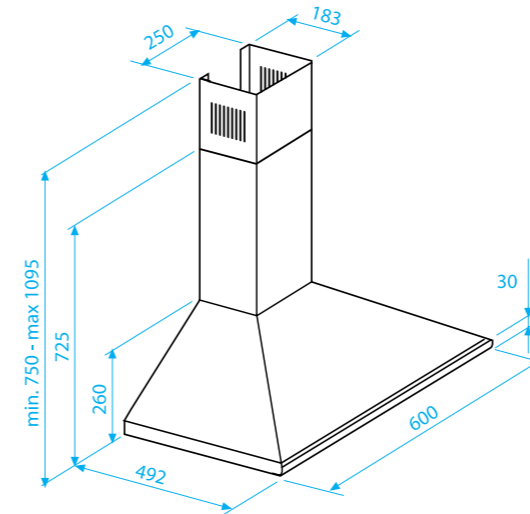

CWB 6420 X

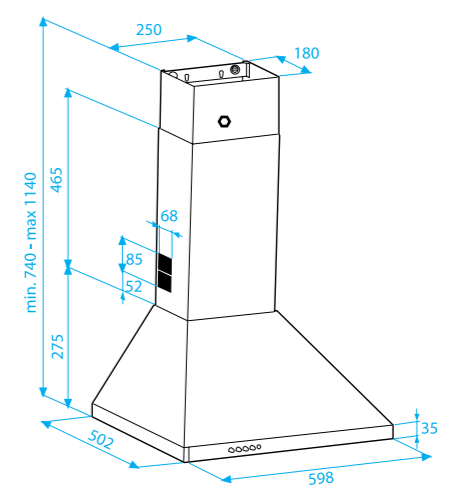

CTB 6407 X/W

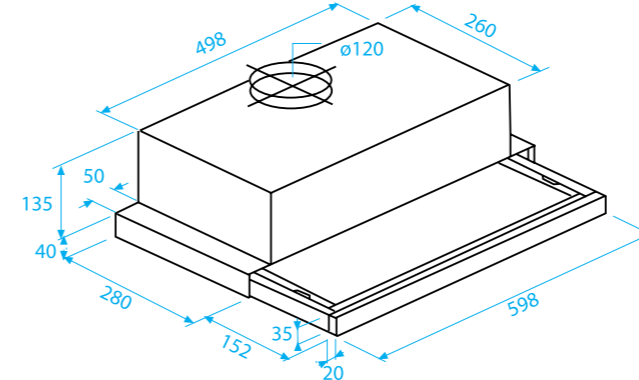

CFB 9433 X

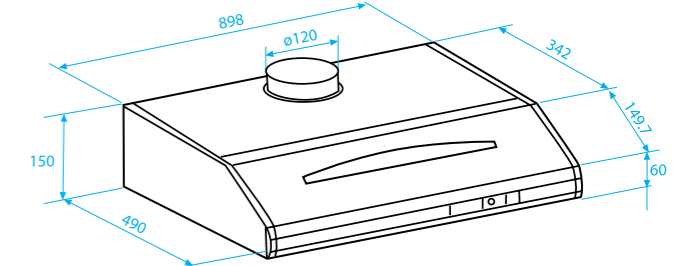

## Cooker Hoods



MODEL CODE	CFB 9431 W	CFB 6436 X	CFB 6433 X	CFB 6432 XG
Type	Standard	Standard	Standard	Standard
Width category (mm)	900	600	600	600
Colour	White	Inox	Inox	Inox
<b>FEATURES</b>				
Type of control	Slider switch	Slider switch	Slider switch	Slider switch
Number of speeds	3	3	3	3
Number of motors	2	2	2	1
Extraction capacity (m³/h)	450	450	450	300
Number of lights and wattage	2x40 W	2x40 W	2x40 W	1x40 W
Grease filter	1xMetal grid	2xAluminium cassette	2xAluminium cassette	1xMetal grid
Glass visor	-	-	-	-
<b>ENERGY CONNECTIONS</b>				
Total power (W)	330	330	330	180
Voltage (V)	220-240	220-240	220-240	220-240
Frequency (Hz)	50	50	50	50
Amperage (A)	10	10	10	10
<b>DIMENSIONS</b>				
Height (mm)	150	150	150	150
Width (mm)	898	598	598	598
Depth (mm)	490	490	490	490
Gross weight (kg)	10.7	9.6	9.6	7.6
Net weight (kg)	9.4	8.5	8.5	6.7

CFB 9431 W

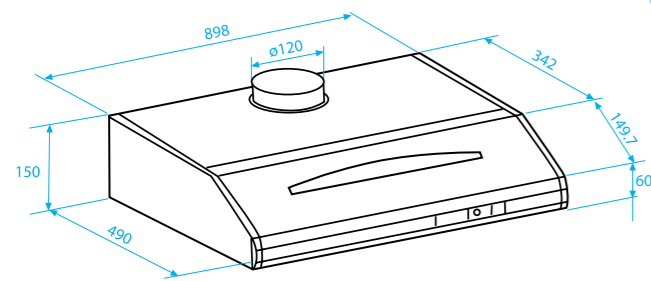

CFB 6436 X

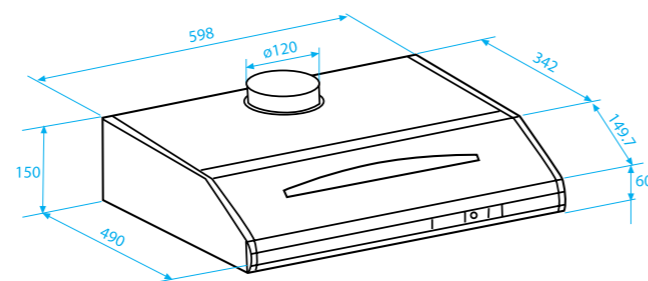

CFB 6433 X

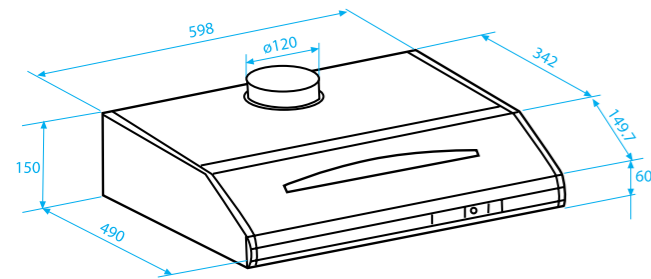

## Cooker Hoods



MODEL CODE	CFB 6432 X	CFB 6434 S	CFB 6432 W	CFB 6431 W
Type	Standard	Standard	Standard	Standard
Width category (mm)	600	600	600	600
Colour	Inox	Silver	White	White
<b>FEATURES</b>				
Type of control	Slider switch	Slider switch	Slider switch	Slider switch
Number of speeds	3	3	3	3
Number of motors	1	2	1	1
Extraction capacity (m³/h)	300	450	300	300
Number of lights and wattage	1x40 W	2x40 W	1x40 W	1x40 W
Grease filter	1xMetal grid	1xMetal grid	1xMetal grid	1xSynthetic
Glass visor	-	-	-	-
<b>ENERGY CONNECTIONS</b>				
Total power (W)	180	330	180	180
Voltage (V)	220-240	220-240	220-240	220-240
Frequency (Hz)	50	50	50	50
Amperage (A)	10	10	10	10
<b>DIMENSIONS</b>				
Height (mm)	150	150	150	150
Width (mm)	598	598	598	598
Depth (mm)	490	490	490	490
Gross weight (kg)	7.4	9.1	7.9	7.8
Net weight (kg)	6.5	8.1	7	6.9

CFB 6432 X | CFB 6432 W

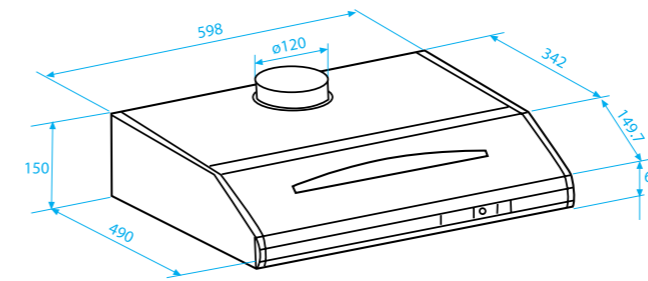

CFB 6431 W

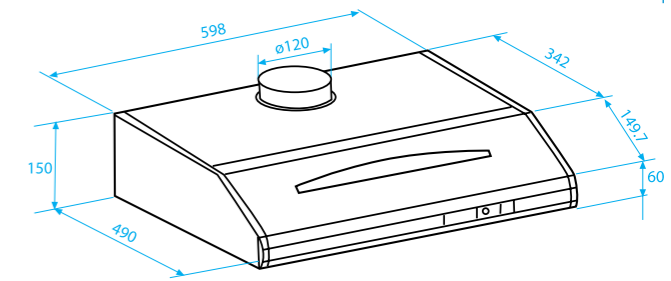

CFB 6434 S

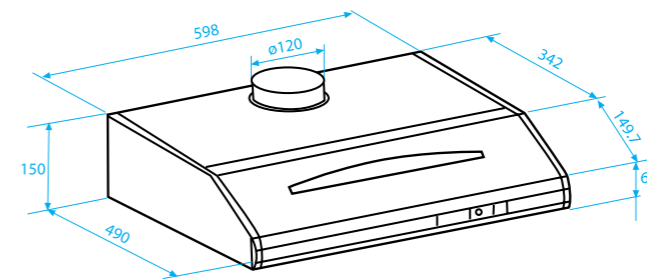

## Cooker Hoods



MODEL CODE	CFB 6437 W	CFB 5432 W
Type	Standard	Standard
Width category (mm)	600	500
Colour	White	White
<b>FEATURES</b>		
Type of control	Slider switch	Slider switch
Number of speeds	3	3
Number of motors	1	1
Extraction capacity (m <sup>3</sup> /h)	255	300
Number of lights and wattage	1x40 W	1x40 W
Grease filter	1xSynthetic	1xMetal grid
Glass visor	-	-
<b>ENERGY CONNECTIONS</b>		
Total power (W)	165	180
Voltage (V)	220-240	220-240
Frequency (Hz)	50	50
Amperage (A)	10	10
<b>DIMENSIONS</b>		
Height (mm)	150	150
Width (mm)	598	498
Depth (mm)	490	490
Gross weight (kg)	7.6	6.6
Net weight (kg)	6.7	5.8

CFB 6437 W

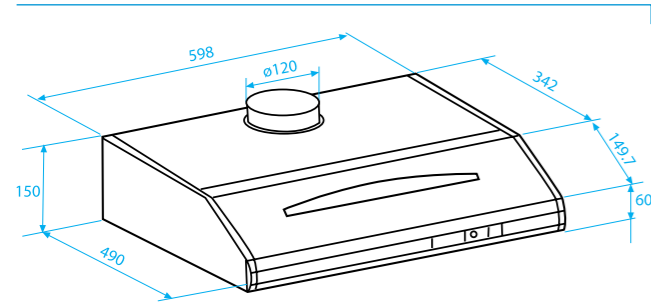

CFB 5432 W

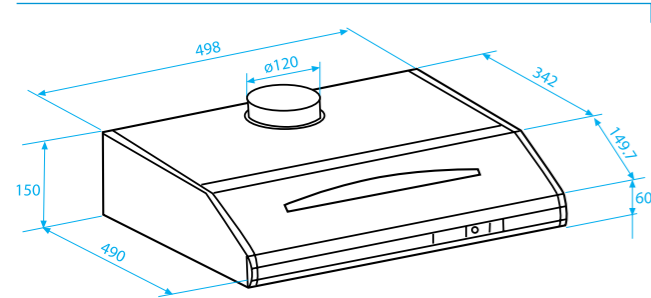

# Dishwashers

## Dishwashers



MODEL CODE	DSN 6839 FX	DSN 6839 FX Extra	DSN 6838 X	DSN 6834 FX
Type	60 cm Semi-Integrated	60 cm Semi-Integrated	60 cm Semi-Integrated	60 cm Semi-Integrated
Semi-integrated	•	•	•	•
Fully integrated				
Built-under				
Colour options				
Stainless steel-X	•	•	•	•
Stainless steel look-XP				
White				
Black-B				
<b>SPECIFICATIONS</b>				
Loading capacity (place settings)	12	15	12	12
Container inox/Plastic	-/-	-/-	-/-	-/-
Inner door inox/Plastic	-/-	-/-	-/-	-/-
Number of programs	8	8	8	8
Program temperatures	35/40/50/55/65/70	35/40/50/55/65/70	35/40/50/60/65/70	35/40/50/60/65/70
Auto wash program	•	•	•	•
Half load	•	•	•	•
Active fan drying	•	•	•	•
Display	• (LCD)	• (LCD)	• (LCD)	• (LCD)
Delayed start	•	•	•	•
Remaining time indicator	•	•	•	•
Program follower	•	•	•	•
Child lock	•	•	•	•
Filter	Metal	Metal	Metal	Metal
Salt indicator mechanical/electronic	-/-	-/-	-/-	-/-
Rinse aid indicator mechanical/electronic	-/-	-/-	-/-	-/-
Power on/off indicator	•	•	•	•
Water softener	•	•	•	•
Water safety system	Waterstop 1 valve	Waterstop 1 valve	Waterstop 1 valve	Waterstop 1 valve
<b>PERFORMANCE</b>				
Reference program	Eco 50 oC	Eco 50 oC	Eco 50 oC	Eco 50 oC
Energy efficiency class	A	A	A	A
Energy consumption (kWh)	1.05	1.10	1	1
Cleaning performance	A	A	A	A
Drying performance	A	A	A	A
Water consumption (liters)	13	14	13	13
Reference program duration (min)	155	170	155	155
Minimum program duration (min)	20	20	20	20
Noise level-IEC 704 (db(A))	46	46	46	46
<b>DIMENSIONS</b>				
Niche dimensions (hxwx) (cm)	82-92x59.8x54.8	82-92x59.8x54.8	82-92x59.8x54.8	82-92x59.8x54.8
Height (cm)	82	82	82	82
Width (cm)	59.8	59.8	59.8	59.8
Depth including wall distance (cm)	54.8	54.8	54.8	54.8
Depth with door opened (cm)	115	115	115	115
Height adjustment (cm)	5	5	5	5
Net weight (kg)	42	42	41	42
Gross weight (kg)	43,5	43,5	42,5	43,5
Packed dimensions (hxwx) (cm)	86.4x64.4x65.1	86.4x64.4x65.1	86.4x64.4x65.1	86.4x64.4x65.1
<b>ENERGY AND WATER CONNECTIONS</b>				
Voltage (V)	220-240	220-240	220-240	220-240
Connected value (W)	2200	2200	2200	2200
Frequency (Hz)	50	50	50	50
Maxcurrent intensity (A)	10	10	10	10
Water supply connection 3/4"	•	•	•	•
Water pressure range (N/cm <sup>2</sup> )	3 to 100	3 to 100	3 to 100	3 to 100
Connection to warm water up to (OC)	60	60	60	60
Cable length (m)	1,8	1,8	1,8	1,8
Maximum possible height from floor to water connection (cm)	110	110	110	110
Maximum possible hose length (cm)	400	400	400	400
<b>RACKS/BASKETS</b>				
Easy fold plate supports	•	•	•	•
Lower rack handle	•	•	•	•
3 Way split cutlery basket	•	•	•	•
Upper rack height adjustment	-/Acrobat system	-/Acrobat system	-/Acrobat system	-/Acrobat system
Upper rack number of shelves	4	4	4	4
Upper rack shelf height adjustment	•	•	•	•
<b>PROGRAMS</b>				
1	Xpress 20'	Xpress 20'	Xpress 20'	Prewash
2	Mini 30' 35°C	Mini 30' 35°C	Mini 30' 35°C	Mini 30' 35°C
3	Delicate 40°C	Delicate 40°C	Delicate 40°C	Delicate 40°C
4	Eco 50°C	Eco 50°C	Eco 50°C	Eco 50°C
5	Quick&Clean 60°C	Quick&Clean 60°C	Quick&Clean 60°C	Quick&Clean 60°C
6	Intensive 65°C	Intensive 65°C	Intensive 65°C	Intensive 65°C
7	Baby care 70°C	Baby care 70°C	Baby care 70°C	Baby care 70°C
8	Auto 40-65°C	Auto 40-65°C	Auto 40-65°C	Auto 40-65°C

## Dishwashers



MODEL CODE	DSN 6833 X	DSN 6834 X Extra	DSN 6834 B Extra	DSN 6834 Extra
Type	60 cm Semi-Integrated	60 cm Semi-Integrated	60 cm Semi-Integrated	60 cm Semi-Integrated
Semi-integrated	•	•	•	•
Fully integrated				
Built-under				
Colour options				
Stainless steel-X	•	•		
Stainless steel look-XP				
White				•
Black-B			•	
<b>SPECIFICATIONS</b>				
Loading capacity (place settings)	12	15	15	15
Container inox/Plastic	-/-	-/-	-/-	-/-
Inner door inox/Plastic	-/-	-/-	-/-	-/-
Number of programs	8	8	8	8
Program temperatures	35/40/50/60/65/70	35/40/50/60/65/70	35/40/50/60/65/70	35/40/50/60/65/70
Auto wash program	•	•	•	•
Half load	•	•	•	•
Active fan drying	•	•	•	•
Display	• (LCD)	• (LCD)	• (LCD)	• (LCD)
Delayed start	•	•	•	•
Remaining time indicator	•	•	•	•
Program follower	•	•	•	•
Child lock	•	•	•	•
Filter	Metal	Metal	Metal	Metal
Salt indicator mechanical/electronic	-/-	-/-	-/-	-/-
Rinse aid indicator mechanical/electronic	-/-	-/-	-/-	-/-
Power on/off indicator	•	•	•	•
Water softener	•	•	•	•
Water safety system	Watersafe	Watersafe	Watersafe	Watersafe
<b>PERFORMANCE</b>				
Reference program	Eco 50 oC	Eco 50 oC	Eco 50 oC	Eco 50 oC
Energy efficiency class	A	A	A	A
Energy consumption (kWh)	1	1	1	1
Cleaning performance	A	A	A	A
Drying performance	A	A	A	A
Water consumption (liters)	13	14	14	14
Reference program duration (min)	155	170	170	170
Minimum program duration (min)	20	20	20	20
Noise level-IEC 704 (db(A))	48	48	48	48
<b>DIMENSIONS</b>				
Niche dimensions (hxwx) (cm)	82-92x59.8x54.8	82-92x59.8x54.8	82-92x59.8x54.8	82-92x59.8x54.8
Height (cm)	82	82	82	82
Width (cm)	59.8	59.8	59.8	59.8
Depth including wall distance (cm)	54.8	54.8	54.8	54.8
Depth with door opened (cm)	115	115	115	115
Height adjustment (cm)	5	5	5	5
Net weight (kg)	41	41	41	41
Gross weight (kg)	42,5	42,5	42,5	42,5
Packed dimensions (hxwx) (cm)	86.4x64.4x65.1	86.4x64.4x65.1	86.4x64.4x65.1	86.4x64.4x65.1
<b>ENERGY AND WATER CONNECTIONS</b>				
Voltage (V)	220-240	220-240	220-240	220-240
Connected value (W)	2200	2200	2200	2200
Frequency (Hz)	50	50	50	50
Maxcurrent intensity (A)	10	10	10	10
Water supply connection 3/4"	•	•	•	•
Water pressure range (N/cm <sup>2</sup> )	3 to 100	3 to 100	3 to 100	3 to 100
Connection to warm water up to (OC)	60	60	60	60
Cable length (m)	1,8	1,8	1,8	1,8
Maximum possible height from floor to water connection (cm)	110	110	110	110
Maximum possible hose length (cm)	400	400	400	400
<b>RACKS/BASKETS</b>				
Easy fold plate supports	•	•	•	•
Lower rack handle	•	•	•	•
3 Way split cutlery basket	•	•	•	•
Upper rack height adjustment	-/Acrobat system	-/Acrobat system	-/Acrobat system	-/Acrobat system
Upper rack number of shelves	4	4	4	4
Upper rack shelf height adjustment	•	•	•	•
<b>PROGRAMS</b>				
1	Prewash	Prewash	Prewash	Prewash
2	Mini 30' 35°C	Mini 30' 35°C	Mini 30' 35°C	Mini 30' 35°C
3	Delicate 40°C	Delicate 40°C	Delicate 40°C	Delicate 40°C
4	Eco 50°C	Eco 50°C	Eco 50°C	Eco 50°C
5	Quick&Clean 60°C	Quick&Clean 60°C	Quick&Clean 60°C	Quick&Clean 60°C
6	Intensive 65°C	Intensive 65°C	Intensive 65°C	Intensive 65°C
7	Baby care 70°C	Baby care 70°C	Baby care 70°C	Baby care 70°C
8	Auto 40-65°C	Auto 40-65°C	Auto 40-65°C	Auto 40-65°C



## Dishwashers



MODEL CODE	DSN 6534 FX	DSN 6533 X	DSN 4530 FX	DSN 2521 X
Type	60 cm Semi-Integrated	60 cm Semi-Integrated	60 cm Semi-Integrated	60 cm Semi-Integrated
Semi-integrated	•	•	•	•
Fully integrated				
Built-under				
Colour options				
Stainless steel-X	•	•	•	•
Stainless steel look-XP				
White				
Black-B				
<b>SPECIFICATIONS</b>				
Loading capacity (place settings)	12	12	12	12
Container inox/Plastic	•/•	•/•	•/•	•/•
Inner door inox/Plastic	•/•	•/•	•/•	•/•
Number of programs	5	5	5	5
Program temperatures	35/50/60/70	35/50/60/70	35/50/60/70	35/50/60/70
Auto wash program				
Half load	•	•	•	•
Active fan drying				
Display	• (LCD)	• (LCD)		
Delayed start	•	•		•
Remaining time indicator	•	•		
Program follower	•	•	•	•
Child lock	•	•		
Filter	Metal	Metal	Metal	Metal
Salt indicator mechanical/electronic	•/•	•/•	•/•	•/•
Rinse aid indicator mechanical/electronic	•/•	•/•	•/•	•/•
Power on/off indicator	•	•	•	•
Water softener	•	•	•	•
Water safety system	Waterstop 1 valve	Waterstop 1 valve	Watersafe	Watersafe
<b>PERFORMANCE</b>				
Reference program	Eco 50 oC	Eco 50 oC	Eco 50 oC	Eco 50 oC
Energy efficiency class	A	A	A	A
Energy consumption (kWh)	1.05	1	1.05	1.05
Cleaning performance	A	A	A	A
Drying performance	A	A	A	A
Water consumption (liters)	13	13	15	15
Reference program duration (min)	155	155	150	136
Minimum program duration (min)	30	30	30	30
Noise level-IEC 704 (db(A))	48	48	50	50
<b>DIMENSIONS</b>				
Niche dimensions (hxwx) (cm)	82-92x59.8x54.8	82-92x59.8x54.8	82-92x59.8x54.8	82-92x59.8x54.8
Height (cm)	82	82	82	82
Width (cm)	59.8	59.8	59.8	59.8
Depth including wall distance (cm)	54.8	54.8	54.8	54.8
Depth with door opened (cm)	115	115	115	115
Height adjustment (cm)	5	5	5	5
Net weight (kg)	42	41	41,5	38
Gross weight (kg)	43,5	42,5	43	40,5
Packed dimensions (hxwx) (cm)	86.4x64.4x65.1	86.4x64.4x65.1	86.4x64.4x65.1	86.4x64.4x65.1
<b>ENERGY AND WATER CONNECTIONS</b>				
Voltage (V)	220-240	220-240	220-240	220-240
Connected value (W)	2200	2200	2200	2200
Frequency (Hz)	50	50	50	50
Maxcurrent intensity (A)	10	10	10	10
Water supply connection 3/4"	•	•	•	•
Water pressure range (N/cm <sup>2</sup> )	3 to 100	3 to 100	3 to 100	3 to 100
Connection to warm water up to (0C)	60	60	25	25
Cable length (m)	1,8	1,8	1,8	1,8
Maximum possible height from floor to water connection (cm)	110	110	110	110
Maximum possible hose length (cm)	400	400	400	400
<b>RACKS/BASKETS</b>				
Easy fold plate supports	•	•	•	•
Lower rack handle	•	•	•	•
3 Way split cutlery basket				
Upper rack height adjustment	•/Acrobat system	•/Acrobat system	•/Acrobat system	•
Upper rack number of shelves	4	4	4	4
Upper rack shelf height adjustment	•	•	•	•
<b>PROGRAMS</b>				
1	Prewash	Prewash	Prewash	Prewash
2	Mini 30' 35°C	Mini 30' 35°C	Mini 30' 35°C	Mini 30' 35°C
3	Eco 50°C	Eco 50°C	Eco 50°C	Eco 50°C
4	Quick&Clean 60°C	Quick&Clean 60°C	Quick&Clean 60°C	Quick&Clean 60°C
5	Intensive 70°C	Intensive 70°C	Intensive 70°C	Intensive 70°C
6				
7				
8				

## Dishwashers



MODEL CODE	DSN 2521 B	DSN 2521	DSN 2501 X	DSN 1521 X
Type	60 cm Semi-Integrated	60 cm Semi-Integrated	60 cm Semi-Integrated	60 cm Semi-Integrated
Semi-integrated	•	•	•	•
Fully integrated				
Built-under				
Colour options				
Stainless steel-X			•	•
Stainless steel look-XP				
White		•		
Black-B	•			
<b>SPECIFICATIONS</b>				
Loading capacity (place settings)	12	12	12	12
Container inox/Plastic	•/•	•/•	•/•	•/•
Inner door inox/Plastic	•/•	•/•	•/•	•/•
Number of programs	5	5	5	5
Program temperatures	35/50/60/70	35/50/60/70	35/50/60/70	35/50/60/70
Auto wash program				
Half load	•	•		
Active fan drying				
Display				
Delayed start	•	•	•	•
Remaining time indicator				
Program follower	•	•	•	•
Child lock				
Filter	Metal	Metal	Metal	Metal
Salt indicator mechanical/electronic	•/•	•/•	•/•	•/•
Rinse aid indicator mechanical/electronic	•/•	•/•	•/•	•/•
Power on/off indicator	•	•	•	•
Water softener	•	•	•	•
Water safety system	Watersafe	Watersafe	Watersafe	Watersafe
<b>PERFORMANCE</b>				
Reference program	Eco 50 oC	Eco 50 oC	Eco 50 oC	Eco 50 oC
Energy efficiency class	A	A	A	A
Energy consumption (kWh)	1.05	1.05	1.05	1.05
Cleaning performance	A	A	A	A
Drying performance	A	A	B	A
Water consumption (liters)	15	15	15	15
Reference program duration (min)	136	136	136	136
Minimum program duration (min)	30	30	30	30
Noise level-IEC 704 (db(A))	50	50	50	52
<b>DIMENSIONS</b>				
Niche dimensions (hxwx) (cm)	82-92x59.8x54.8	82-92x59.8x54.8	82-92x59.8x54.8	82-92x45x57
Height (cm)	82	82	82	82
Width (cm)	59.8	59.8	59.8	44.8
Depth including wall distance (cm)	54.8	54.8	54.8	54.8
Depth with door opened (cm)	115	115	115	115
Height adjustment (cm)	5	5	5	5
Net weight (kg)	38	38	38	38
Gross weight (kg)	40,5	40,5	40,5	40,5
Packed dimensions (hxwx) (cm)	86.4x64.4x65.1	86.4x64.4x65.1	86.4x64.4x65.1	85.9x49.4x66.1
<b>ENERGY AND WATER CONNECTIONS</b>				
Voltage (V)	220-240	220-240	220-240	220-240
Connected value (W)	2200	2200	2200	2200
Frequency (Hz)	50	50	50	50
Maxcurrent intensity (A)	10	10	10	10
Water supply connection 3/4"	•	•	•	•
Water pressure range (N/cm <sup>2</sup> )	3 to 100	3 to 100	3 to 100	3 to 100
Connection to warm water up to (0C)	25	25	25	25
Cable length (m)	1,8	1,8	1,8	1,8
Maximum possible height from floor to water connection (cm)	110	110	110	110
Maximum possible hose length (cm)	400	400	400	400
<b>RACKS/BASKETS</b>				
Easy fold plate supports	•	•	•	•
Lower rack handle	•	•	•	•
3 Way split cutlery basket				
Upper rack height adjustment	•	•	•	•
Upper rack number of shelves	4	4	4	4
Upper rack shelf height adjustment	•	•	•	•
<b>PROGRAMS</b>				
1	Prewash	Prewash	Prewash	Prewash
2	Mini 30' 35°C	Mini 30' 35°C	Mini 30' 35°C	Mini 30' 35°C
3	Eco 50°C	Eco 50°C	Eco 50°C	Eco 50°C
4	Quick&Clean 60°C	Quick&Clean 60°C	Quick&Clean 60°C	Quick&Clean 60°C
5	Intensive 70°C	Intensive 70°C	Intensive 70°C	Intensive 70°C
6				
7				
8				

## Dishwashers



MODEL CODE	DSN 1501 X	DSN 1421 X	DSN 1401 X	DSN 1321 X
Type	60 cm Semi-Integrated	60 cm Semi-Integrated	60 cm Semi-Integrated	60 cm Semi-Integrated
Semi-integrated	.	.	.	.
Fully integrated				
Built-under				
Colour options				
Stainless steel-X	.	.	.	.
Stainless steel look-XP				
White				
Black-B				
<b>SPECIFICATIONS</b>				
Loading capacity (place settings)	12	12	12	12
Container inox/Plastic	·/·	·/·	·/·	·/·
Inner door inox/Plastic	·/·	·/·	·/·	·/·
Number of programs	5	4	4	3
Program temperatures	35/50/60/70	50/60/70	50/60/70	50/70
Auto wash program				
Half load				
Active fan drying				
Display				
Delayed start				
Remaining time indicator				
Program follower	.	.	.	.
Child lock				
Filter	Metal	Plastic	Plastic	Plastic
Salt indicator mechanical/electronic	·/·	·/·	·/·	·/·
Rinse aid indicator mechanical/electronic	·/·	·/·	·/·	·/·
Power on/off indicator	.	.	.	.
Water softener	.	.	.	.
Water safety system	Watersafe	Watersafe	Watersafe	Waterstop 1 valve
<b>PERFORMANCE</b>				
Reference program	Eco 50 oC	Eco 50 oC	Eco 50	Eco 50
Energy efficiency class	A	A	A	A
Energy consumption (kWh)	1.05	1.05	1.05	1.05
Cleaning performance	A	A	A	A
Drying performance	B	A	B	A
Water consumption (liters)	15	15	15	15
Reference program duration (min)	136	136	136	136
Minimum program duration (min)	30	58	58	115
Noise level-IEC 704 (db(A))	52	54	54	54
<b>DIMENSIONS</b>				
Niche dimensions (hxwx) (cm)	82-92x45x57	82-92x45x57	82-92x59.8x54.8	82-92x59.8x54.8
Height (cm)	82	82	82	82
Width (cm)	44.8	44.8	59.8	59.8
Depth including wall distance (cm)	54.8	54.8	54.8	54.8
Depth with door opened (cm)	115	115	115	115
Height adjustment (cm)	5	5	5	5
Net weight (kg)	38	38	38	38
Gross weight (kg)	40,5	40,5	40,5	40,5
Packed dimensions (hxwx) (cm)	85.9x49.4x66.1		86.4x64.4x65.1	86.4x64.4x65.1
<b>ENERGY AND WATER CONNECTIONS</b>				
Voltage (V)	220-240	220-240	220-240	220-240
Connected value (W)	2200	2200	2200	2200
Frequency (Hz)	50	50	50	50
Maxcurrent intensity (A)	10	10	10	10
Water supply connection 3/4"	.	.	.	.
Water pressure range (N/cm2)	3 to 100	3 to 100	3 To 100	3 To 100
Connection to warm water up to (0C)	25	25	25	60
Cable length (m)	1,8	1,8	1,8	1,8
Maximum possible height from floor to water connection (cm)	110	110	110	110
Maximum possible hose length (cm)	400	400	400	400
<b>RACKS/BASKETS</b>				
Easy fold plate supports	.	.	.	.
Lower rack handle	.	.	.	.
3 Way split cutlery basket				
Upper rack height adjustment	.	.	.	.
Upper rack number of shelves	4	2	2	2
Upper rack shelf height adjustment				
<b>PROGRAMS</b>				
1	Prewash	Prewash	Prewash	Prewash
2	Mini 30' 35°C	Eco 50°C	Eco 50°C	Eco 50°C
3	Eco 50°C	Quick&Clean 60°C	Quick&Clean 60°C	Intensive 65°C
4	Quick&Clean 60°C	Intensive 70°C	Intensive 70°C	
5	Intensive 70°C			
6				
7				
8				

## Dishwashers



MODEL CODE	DSN 1301 X	DSN 1301 XP	DSN 1301 B	DSN 1301
Type	60 cm Semi-Integrated	60 cm Semi-Integrated	60 cm Semi-Integrated	60 cm Semi-Integrated
Semi-integrated	.	.	.	.
Fully integrated				
Built-under				
Colour options				
Stainless steel-X	.	.	.	.
Stainless steel look-XP		.		
White				.
Black-B			.	
<b>SPECIFICATIONS</b>				
Loading capacity (place settings)	12	12	12	12
Container inox/Plastic	·/·	·/·	·/·	·/·
Inner door inox/Plastic	·/·	·/·	·/·	·/·
Number of programs	3	3	3	3
Program temperatures	50/65	50/65	50/65	50/70
Auto wash program				
Half load				
Active fan drying				
Display				
Delayed start				
Remaining time indicator				
Program follower	.	.	.	.
Child lock				
Filter	Plastic	Plastic	Plastic	Plastic
Salt indicator mechanical/electronic	·/·	·/·	·/·	·/·
Rinse aid indicator mechanical/electronic	·/·	·/·	·/·	·/·
Power on/off indicator	.	.	.	.
Water softener	.	.	.	.
Water safety system	Watersafe	Watersafe	Watersafe	Watersafe
<b>PERFORMANCE</b>				
Reference program	Eco 50	WOS042	WOS042	WOS042
Energy efficiency class	A	A	A	A
Energy consumption (kWh)	1.05	1.05	1.05	1.05
Cleaning performance	A	A	A	A
Drying performance	B	B	B	B
Water consumption (liters)	15	15	15	15
Reference program duration (min)	136	136	136	136
Minimum program duration (min)	115	115	115	115
Noise level-IEC 704 (db(A))	54	54	54	54
<b>DIMENSIONS</b>				
Niche dimensions (hxwx) (cm)	82-92x59.8x54.8	82-92x59.8x54.8	82-92x59.8x54.8	82-92x59.8x54.8
Height (cm)	82	82	82	82
Width (cm)	59.8	59.8	59.8	59.8
Depth including wall distance (cm)	54.8	54.8	54.8	54.8
Depth with door opened (cm)	115	115	115	115
Height adjustment (cm)	5	5	5	5
Net weight (kg)	38	38	38	38
Gross weight (kg)	40,5	40,5	40,5	40,5
Packed dimensions (hxwx) (cm)	86.4x64.4x65.1	86.4x64.4x65.1	86.4x64.4x65.1	86.4x64.4x65.1
<b>ENERGY AND WATER CONNECTIONS</b>				
Voltage (V)	220-240	220-240	220-240	220-240
Connected value (W)	2200	2200	2200	2200
Frequency (Hz)	50	50	50	50
Maxcurrent intensity (A)	10	10	10	10
Water supply connection 3/4"	.	.	.	.
Water pressure range (N/cm2)	3 to 100	3 to 100	3 to 100	3 to 100
Connection to warm water up to (0C)	60	60	60	60
Cable length (m)	1,8	1,8	1,8	1,8
Maximum possible height from floor to water connection (cm)	110	110	110	110
Maximum possible hose length (cm)	400	400	400	400
<b>RACKS/BASKETS</b>				
Easy fold plate supports				
Lower rack handle				
3 Way split cutlery basket				
Upper rack height adjustment	.	.	.	.
Upper rack number of shelves	2	2	2	2
Upper rack shelf height adjustment				
<b>PROGRAMS</b>				
1	Prewash	Prewash	Prewash	Prewash
2	Eco 50°C	Eco 50°C	Eco 50°C	Eco 50°C
3	Intensive 65°C	Intensive 65°C	Intensive 65°C	Intensive 65°C
4				
5				
6				
7				
8				

## Dishwashers



MODEL CODE	DIN 5832	DIN 5832 XL	DIN 5832 Extra	DDN 5832 X
Type	60 cm Full-Integrated	60 cm Full-Integrated	60 cm Full-Integrated	60 cm Built-Under
Semi-integrated				
Fully integrated	•	•	•	
Built-under				•
Colour options				•
Stainless steel-X				•
Stainless steel look-XP				•
White	•	•	•	
Black-B				
<b>SPECIFICATIONS</b>				
Loading capacity (place settings)	12	12	15	12
Container inox/Plastic	-/-	-/-	-/-	-/-
Inner door inox/Plastic	-/-	-/-	-/-	-/-
Number of programs	8	8	8	8
Program temperatures	35/40/50/60/65/70	35/40/50/60/65/70	35/40/50/60/65/70	35/40/50/60/65/70
Auto wash program	•	•	•	•
Half load	•	•	•	•
Active fan drying	•	•	•	•
Display	•(Digital)	•(Digital)	•(Digital)	•(Digital)
Delayed start	•	•	•	•
Remaining time indicator				
Program follower				
Child lock				
Filter	Metal	Metal	Metal	Metal
Salt indicator mechanical/electronic	-/-	-/-	-/-	-/-
Rinse aid indicator mechanical/electronic	-/-	-/-	-/-	-/-
Power on/off indicator	•	•	•	•
Water softener	•	•	•	•
Water safety system	Waterstop 1 valve	Waterstop 1 valve	Waterstop 1 valve	Waterstop 1 valve
<b>PERFORMANCE</b>				
Reference program	Eco 50	Eco 50	Eco 50	Eco 50
Energy efficiency class	A	A	A	A
Energy consumption (kWh)	1.05	1.05	1.10	1.05
Cleaning performance	A	A	A	A
Drying performance	A	A	A	A
Water consumption (liters)	13	13	14	13
Reference program duration (min)	170	170	170	170
Minimum program duration (min)	30	30	30	30
Noise level-IEC 704 (db(A))	48	48	48	48
<b>DIMENSIONS</b>				
Niche dimensions (hxwx) (cm)	82-92x59.8x54.8	86-92x59.8x54.8	82-92x59.8x54.8	82-92x59.8x54.8
Height (cm)	82	86	82	82
Width (cm)	59.8	59.8	59.8	59.8
Depth including wall distance (cm)	54.8	54.8	54.8	54.8
Depth with door opened (cm)	115	119	115	115
Height adjustment (cm)	10	10	10	10
Net weight (kg)	38	38	38	41
Gross weight (kg)	40,5	40,5	40,5	43,5
Packed dimensions (hxwx) (cm)	86.4x64.4x65.1	86.4x64.4x65.1	86.4x64.4x65.1	86.4x64.4x65.1
<b>ENERGY AND WATER CONNECTIONS</b>				
Voltage (V)	220-240	220-240	220-240	220-240
Connected value (W)	2200	2200	2200	2200
Frequency (Hz)	50	50	50	50
Maxcurrent intensity (A)	10	10	10	10
Water supply connection 3/4"	•	•	•	•
Water pressure range (N/cm <sup>2</sup> )	3 to 100	3 to 100	3 to 100	3 to 100
Connection to warm water up to (0C)	60	60	60	60
Cable length (m)	1,8	1,8	1,8	1,8
Maximum possible height from floor to water connection (cm)	110	110	110	110
Maximum possible hose length (cm)	400	400	400	400
<b>RACKS/BASKETS</b>				
Easy fold plate supports	•	•	•	•
Lower rack handle	•	•	•	•
3 Way split cutlery basket	•	•	•	•
Upper rack height adjustment	•/Acrobat System	•/Acrobat System	•/Acrobat System	•/Acrobat System
Upper rack number of shelves	4	4	4	4
Upper rack shelf height adjustment	•	•	•	•
<b>PROGRAMS</b>				
1	Prewash	Prewash	Prewash	Prewash
2	Mini 30' 35°C	Mini 30' 35°C	Mini 30' 35°C	Mini 30' 35°C
3	Delicate 40°C	Delicate 40°C	Delicate 40°C	Delicate 40°C
4	Eco 50°C	Eco 50°C	Eco 50°C	Eco 50°C
5	Quick&Clean 60°C	Quick&Clean 60°C	Quick&Clean 60°C	Quick&Clean 60°C
6	Intensive 65°C	Intensive 65°C	Intensive 65°C	Intensive 65°C
7	Baby care 70°C	Baby care 70°C	Baby care 70°C	Baby care 70°C
8	Auto 40-65°C	Auto 40-65°C	Auto 40-65°C	Auto 40-65°C

## Dishwashers



MODEL CODE	DDN 5832 XXL	DDN 5832 Extra	DIN 1530	DIN 1535 Extra
Type	60 cm Built-Under Tall Tub	60 cm Built-Under	60 cm Full-Integrated	60 cm Full-Integrated
Semi-integrated				
Fully integrated			•	•
Built-under	•	•		
Colour options				
Stainless steel-X	•	•		
Stainless steel look-XP				
White			•	•
Black-B				
<b>SPECIFICATIONS</b>				
Loading capacity (place settings)	12	15	12	15
Container inox/Plastic	-/-	-/-	-/-	-/-
Inner door inox/Plastic	-/-	-/-	-/-	-/-
Number of programs	8	8	5	5
Program temperatures	35/40/50/60/65/70	35/40/50/60/65/70	35/50/60/70	35/50/60/70
Auto wash program	•	•		
Half load	•	•	•	•
Active fan drying	•	•		
Display	•(Digital)	•(Digital)		
Delayed start	•	•		
Remaining time indicator				
Program follower				
Child lock				
Filter	Metal	Metal	Metal	Metal
Salt indicator mechanical/electronic	-/-	-/-	-/-	-/-
Rinse aid indicator mechanical/electronic	-/-	-/-	-/-	-/-
Power on/off indicator	•	•	•	•
Water softener	•	•	•	•
Water safety system	Waterstop 1 valve	Waterstop 1 valve	Waterstop 1 valve	Waterstop 1 valve
<b>PERFORMANCE</b>				
Reference program	Eco 50	Eco 50	Eco 50	Eco 50
Energy efficiency class	A	A	A	A
Energy consumption (kWh)	1.05	1.10	1.05	1.10
Cleaning performance	A	A	A	A
Drying performance	A	A	A	A
Water consumption (liters)	13	14	15	16
Reference program duration (min)	170	170	136	140
Minimum program duration (min)	30	30	30	30
Noise level-IEC 704 (db(A))	48	48	50	50
<b>DIMENSIONS</b>				
Niche dimensions (hxwx) (cm)	86-92x59.8x54.8	82-92x59.8x54.8	82-92x59.8x54.8	82-92x59.8x54.8
Height (cm)	86	82	82	82
Width (cm)	59.8	59.8	59.8	59.8
Depth including wall distance (cm)	54.8	54.8	54.8	54.8
Depth with door opened (cm)	119	115	115	115
Height adjustment (cm)	10	10	10	10
Net weight (kg)	41	41	38	38
Gross weight (kg)	43,5	43,5	40,5	40,5
Packed dimensions (hxwx) (cm)	86.4x64.4x65.1	86.4x64.4x65.1	86.4x64.4x65.1	86.4x64.4x65.1
<b>ENERGY AND WATER CONNECTIONS</b>				
Voltage (V)	220-240	220-240	230	230
Connected value (W)	2200	2200	2200	2200
Frequency (Hz)	50	50	50	50
Maxcurrent intensity (A)	10	10	10	10
Water supply connection 3/4"	•	•	•	•
Water pressure range (N/cm <sup>2</sup> )	3 to 100	3 to 100	3 to 100	3 to 100
Connection to warm water up to (0C)	60	60	60	60
Cable length (m)	1,8	1,8	1,8	1,8
Maximum possible height from floor to water connection (cm)	110	110	110	110
Maximum possible hose length (cm)	400	400	400	400
<b>RACKS/BASKETS</b>				
Easy fold plate supports	•	•	•	•
Lower rack handle	•	•	•	•
3 Way split cutlery basket	•	•	•	•
Upper rack height adjustment	•/Acrobat System	•/Acrobat System	•	•
Upper rack number of shelves	4	4	4	4
Upper rack shelf height adjustment	•	•	•	•
<b>PROGRAMS</b>				
1	Prewash	Prewash	Prewash	Prewash
2	Mini 30' 35°C	Mini 30' 35°C	Mini 30' 35°C	Mini 30' 35°C
3	Delicate 40°C	Delicate 40°C	Eco 50°C	Eco 50°C
4	Eco 50°C	Eco 50°C	Quick&Clean 60°C	Quick&Clean 60°C
5	Quick&Clean 60°C	Quick&Clean 60°C	Intensive 70°C	Intensive 70°C
6	Intensive 65°C	Intensive 65°C		
7	Baby care 70°C	Baby care 70°C		
8	Auto 40-65°C	Auto 40-65°C		

## Dishwashers



MODEL CODE	DDN 1530 X	DIN 1510	DIN 1421	DIN 1401
Type	60 cm Built-Under	60 cm Full-Integrated	60 cm Full-Integrated	60 cm Full-Integrated
Semi-integrated				
Fully integrated		•	•	•
Built-under	•			
Colour options				
Stainless steel-X	•			
Stainless steel look-XP				
White		•	•	•
Black-B				
<b>SPECIFICATIONS</b>				
Loading capacity (place settings)	12	12	12	12
Container inox/Plastic	-/-	-/-	-/-	-/-
Inner door inox/Plastic	-/-	-/-	-/-	-/-
Number of programs	5	5	4	4
Program temperatures	35/50/60/70	35/50/60/70	35/50/60	35/50/60
Auto wash program				
Half load	•	•		
Active fan drying				
Display				
Delayed start				
Remaining time indicator				
Program follower	•(LED)			
Child lock				
Filter	Metal	Plastic	Plastic	Metal
Salt indicator mechanical/electronic	-/-	-/-	-/-	-/-
Rinse aid indicator mechanical/electronic	-/-	-/-	-/-	-/-
Power on/off indicator	•	•	•	•
Water softener	•	•	•	•
Water safety system	Waterstop 1 valve	Waterstop 1 valve	Watersafe	Watersafe
<b>PERFORMANCE</b>				
Reference program	Eco 50	Eco 50	Eco 50	Eco 50
Energy efficiency class	A	A	A	A
Energy consumption (kWh)	1.05	1.05	1.05	1.05
Cleaning performance	A	A	A	A
Drying performance	A	B	A	B
Water consumption (liters)	15	15	15	15
Reference program duration (min)	136	136	136	136
Minimum program duration (min)	30	30	58	58
Noise level-IEC 704 (db(A))	50	50	50	50
<b>DIMENSIONS</b>				
Niche dimensions (hxwx) (cm)	82-92x59.8x54.8	82-92x59.8x54.8	82-92x59.8x54.8	82-92x59.8x54.8
Height (cm)	82	82	82	82
Width (cm)	59.8	59.8	59.8	59.8
Depth including wall distance (cm)	54.8	54.8	54.8	54.8
Depth with door opened (cm)	115	115	115	115
Height adjustment (cm)	10	10	10	10
Net weight (kg)	41	38	38	38
Gross weight (kg)	43,5	40,5	40,5	40,5
Packed dimensions (hxwx) (cm)	86.4x64.4x65.1	86.4x64.4x65.1	86.4x64.4x65.1	86.4x64.4x65.1
<b>ENERGY AND WATER CONNECTIONS</b>				
Voltage (V)	230	230	230	230
Connected value (W)	2200	2200	2200	2200
Frequency (Hz)	50	50	50	50
Maxcurrent intensity (A)	10	10	10	10
Water supply connection 3/4"	•	•	•	•
Water pressure range (N/cm <sup>2</sup> )	3 to 100	3 to 100	3 to 100	3 to 100
Connection to warm water up to (0C)	60	60	60	60
Cable length (m)	1,8	1,8	1,8	1,8
Maximum possible height from floor to water connection (cm)	110	110	110	110
Maximum possible hose length (cm)	400	400	400	400
<b>RACKS/BASKETS</b>				
Easy fold plate supports	•	•	•	•
Lower rack handle	•	•	•	•
3 Way split cutlery basket				
Upper rack height adjustment	•	•	•	•
Upper rack number of shelves	4	4	4	4
Upper rack shelf height adjustment	•	•	•	•
<b>PROGRAMS</b>				
1	Prewash	Prewash	Prewash	Prewash
2	Mini 30' 35°C	Mini 30' 35°C	Eco 50°C	Eco 50°C
3	Eco 50°C	Eco 50°C	Quick&Clean 60°C	Quick&Clean 60°C
4	Quick&Clean 60°C	Quick&Clean 60°C	Intensive 70°C	Intensive 70°C
5	Intensive 70°C	Intensive 70°C		
6				
7				
8				

## Dishwashers



MODEL CODE	DSS 6830 X	DSS 6630 X	DSS 2521 X	DSS 2501 X
Type	45 cm Semi-Integrated	45 cm Semi-Integrated	45 cm Semi-Integrated	45 cm Semi-Integrated
Semi-integrated	•	•	•	•
Fully integrated				
Built-under				
Colour options				
Stainless steel-X	•	•	•	•
Stainless steel look-XP				
White				
Black-B				
<b>SPECIFICATIONS</b>				
Loading capacity (place settings)	10	10	10	10
Container inox/Plastic	-/-	-/-	-/-	-/-
Inner door inox/Plastic	-/-	-/-	-/-	-/-
Number of programs	8	6	5	5
Program temperatures	35/40/50/60/65/70	35/40/50/60/70	35/50/60/70	35/50/60/70
Auto wash program	•	•		
Half load	•	•		
Active fan drying				
Display	•(LCD)	•(LCD)		
Delayed start	•	•	•	•
Remaining time indicator	•	•	•	•
Program follower	•	•	•	•
Child lock	•	•		
Filter	Metal	Metal	Metal	Plastic
Salt indicator mechanical/electronic	-/-	-/-	-/-	-/-
Rinse aid indicator mechanical/electronic	-/-	-/-	-/-	-/-
Power on/off indicator	•	•	•	•
Water softener	•	•	•	•
Water safety system	Watersafe	Watersafe	Watersafe	Watersafe
<b>PERFORMANCE</b>				
Reference program	Eco 50-N1S040 (10)	Eco 50-N1S040 (10)	Eco 50	Eco 50
Energy efficiency class	A	A	A	A
Energy consumption (kWh)	1.01	1.01	1.01	1.01
Cleaning performance	A	A	A	A
Drying performance	A	A	A	B
Water consumption (liters)	12	12	13	13
Reference program duration (min)	170	170	140	140
Minimum program duration (min)	30	30	30	30
Noise level-IEC 704 (db(A))	48	48	52	52
<b>DIMENSIONS</b>				
Niche dimensions (hxwx) (cm)	82-92x44.8x54.8	82-92x44.8x54.8	82-92x44.8x54.8	82-92x44.8x54.8
Height (cm)	82	82	82	82
Width (cm)	44.8	44.8	44.8	44.8
Depth including wall distance (cm)	54.8	54.8	54.8	54.8
Depth with door opened (cm)	115	115	115	115
Height adjustment (cm)	5	5	5	5
Net weight (kg)	33	33	33	33
Gross weight (kg)	35,5	35,5	35,5	35,5
Packed dimensions (hxwx) (cm)	85.9x49.4x66.1	85.9x49.4x66.1	85.9x49.4x66.1	85.9x49.4x66.1
<b>ENERGY AND WATER CONNECTIONS</b>				
Voltage (V)	220-240	220-240	220-240	220-240
Connected value (W)	2200	2200	2200	2200
Frequency (Hz)	50	50	50	50
Maxcurrent intensity (A)	10	10	10	10
Water supply connection 3/4"	•	•	•	•
Water pressure range (N/cm <sup>2</sup> )	3 to 100	3 to 100	3 to 100	3 to 100
Connection to warm water up to (0C)	25	25	25	25
Cable length (m)	1,8	1,8	1,8	1,8
Maximum possible height from floor to water connection (cm)	110	110	110	110
Maximum possible hose length (cm)	400	400	400	400
<b>RACKS/BASKETS</b>				
Easy fold plate supports	•	•		
Lower rack handle	•	•	•	•
3 Way split cutlery basket				
Upper rack height adjustment				
Upper rack number of shelves	4	4	4	4
Upper rack shelf height adjustment	•	•	•	•
<b>PROGRAMS</b>				
1	Pre-wash	Prewash	Prewash	Prewash
2	Mini 30' 35°C	Mini 30' 35°C	Mini 30' 35°C	Mini 30' 35°C
3	Delicate 40°C	Delicate 40°C	Eco 50°C	Eco 50°C
4	Eco 50°C	Eco 50°C	Quick&Clean 60°C	Quick&Clean 60°C
5	Quick&Clean 60°C	Quick&Clean 60°C	Intensive 70°C	Intensive 70°C
6	Intensive 65°C	Intensive 70°C		
7	Baby care 70°C			
8	Auto 40-65°C			

## Dishwashers



MODEL CODE	DSS 2501 XP	DSS 1301 X	DSS 1301 XP	DIS 5830
Type	45 cm Semi-Integrated	45 cm Semi-Integrated	45 cm Semi-Integrated	45 cm Full-Integrated
Semi-integrated	•	•	•	•
Fully integrated				
Built-under				
Colour options				
Stainless steel-X		•		
Stainless steel look-XP	•		•	
White				•
Black-B				
<b>SPECIFICATIONS</b>				
Loading capacity (place settings)	10	10	10	10
Container inox/Plastic	-/-	-/-	-/-	-/-
Inner door inox/Plastic	-/-	-/-	-/-	-/-
Number of programs	5	3	3	8
Program temperatures	35/50/60/70	50/65	50/65	35/40/50/60/65/70
Auto wash program				•
Half load				•
Active fan drying				
Display				•(Digital)
Delayed start				•
Remaining time indicator				•
Program follower	•	•	•	•
Child lock				•
Filter	Plastic	Plastic	Plastic	Metal
Salt indicator mechanical/electronic	-/-	-/-	-/-	-/-
Rinse aid indicator mechanical/electronic	-/-	-/-	-/-	-/-
Power on/off indicator	•	•	•	•
Water softener	•	•	•	•
Water safety system	Watersafe	Watersafe	Watersafe	Waterstop 1 valve
<b>PERFORMANCE</b>				
Reference program	Eco 50	Eco 50	Eco 50	Eco 50
Energy efficiency class	A	A	A	A
Energy consumption (kWh)	1.01	1.01	1.01	1.01
Cleaning performance	A	A	A	A
Drying performance	B	A	A	A
Water consumption (liters)	13	13	13	12
Reference program duration (min)	140	140	140	170
Minimum program duration (min)	30	115	115	30
Noise level-IEC 704 (db(A))	52	54	54	51
<b>DIMENSIONS</b>				
Niche dimensions (hwxwd) (cm)	82-92x44.8x54.8	82-92x44.8x54.8	82-92x44.8x54.8	82-92x44.8x54.8
Height (cm)	82	82	82	82
Width (cm)	44.8	44.8	44.8	44.8
Depth including wall distance (cm)	54.8	54.8	54.8	54.8
Depth with door opened (cm)	115	115	115	115
Height adjustment (cm)	5	5	5	10
Net weight (kg)	33	33	33	33
Gross weight (kg)	35,5	35,5	35,5	35,5
Packed dimensions (hwxwd) (cm)	85.9x49.4x66.1	85.9x49.4x66.1	85.9x49.4x66.1	85.9x49.4x66.1
<b>ENERGY AND WATER CONNECTIONS</b>				
Voltage (V)	220-240	220-240	220-240	220-240
Connected value (W)	2200	2200	2200	2200
Frequency (Hz)	50	50	50	50
Maxcurrent intensity (A)	10	10	10	10
Water supply connection 3/4"	•	•	•	•
Water pressure range (N/cm2)	3 to 100	3 to 100	3 to 100	3 to 100
Connection to warm water up to (0C)	25	25	25	60
Cable length (m)	1,8	1,8	1,8	1,8
Maximum possible height from floor to water connection (cm)	110	110	110	110
Maximum possible hose length (cm)	400	400	400	400
<b>RACKS/BASKETS</b>				
Easy fold plate supports				•
Lower rack handle	•			•
3 Way split cutlery basket				
Upper rack height adjustment				
Upper rack number of shelves	4	4	4	4
Upper rack shelf height adjustment	•	•	•	•
<b>PROGRAMS</b>				
1	Prewash	Prewash	Prewash	Prewash
2	Mini 30' 35°C	Eco 50°C	Eco 50°C	Mini 30' 35°C
3	Eco 50°C	Intensive 65°C	Intensive 65°C	Delicate 40°C
4	Quick&Clean 60°C			Eco 50°C
5	Intensive 70°C			Normal 55°C
6				Intensive 70°C
7				Hygienic wash 70°C
8				Auto 55-65°C

## Dishwashers



MODEL CODE	DIS 1520	DIS 1501	DIS 1300
Type	45 cm Full-Integrated	45 cm Full-Integrated	45 cm Full-Integrated
Semi-integrated			
Fully integrated	•	•	•
Built-under			
Colour options			
Stainless steel-X			
Stainless steel look-XP			
White	•	•	•
Black-B			
<b>SPECIFICATIONS</b>			
Loading capacity (place settings)	10	10	10
Container inox/Plastic	-/-	-/-	-/-
Inner door inox/Plastic	-/-	-/-	-/-
Number of programs	5	5	3
Program temperatures	35/50/60/70	35/50/60/70	50/65
Auto wash program			
Half load			
Active fan drying			
Display			
Delayed start			
Remaining time indicator			
Program follower			
Child lock			
Filter	Metal	Metal	Metal
Salt indicator mechanical/electronic	-/-	-/-	-/-
Rinse aid indicator mechanical/electronic	-/-	-/-	-/-
Power on/off indicator	•	•	•
Water softener	•	•	•
Water safety system	Waterstop 1 valve	Waterstop 1 valve	Watersafe
<b>PERFORMANCE</b>			
Reference program	Eco 50	Eco 50	Eco 50
Energy efficiency class	A	A	A
Energy consumption (kWh)	1.01	1.01	1.01
Cleaning performance	A	A	A
Drying performance	A	A	A
Water consumption (liters)	13	13	13
Reference program duration (min)	140	140	140
Minimum program duration (min)	30	30	115
Noise level-IEC 704 (db(A))	52	54	54
<b>DIMENSIONS</b>			
Niche dimensions (hwxwd) (cm)	82-92x44.8x54.8	82-92x44.8x54.8	82-92x44.8x54.8
Height (cm)	82	82	82
Width (cm)	44.8	44.8	44.8
Depth including wall distance (cm)	54.8	54.8	54.8
Depth with door opened (cm)	115	115	115
Height adjustment (cm)	10	10	10
Net weight (kg)	33	33	33
Gross weight (kg)	35,5	35,5	35,5
Packed dimensions (hwxwd) (cm)	85.9x49.4x66.1	85.9x49.4x66.1	85.9x49.4x66.1
<b>ENERGY AND WATER CONNECTIONS</b>			
Voltage (V)	220-240	220-240	220-240
Connected value (W)	2200	2200	2200
Frequency (Hz)	50	50	50
Maxcurrent intensity (A)	10	10	10
Water supply connection 3/4"	•	•	•
Water pressure range (N/cm2)	3 to 100	3 to 100	3 to 100
Connection to warm water up to (0C)	60	60	60
Cable length (m)	1,8	1,8	1,8
Maximum possible height from floor to water connection (cm)	110	110	110
Maximum possible hose length (cm)	400	400	400
<b>RACKS/BASKETS</b>			
Easy fold plate supports			
Lower rack handle	•		
3 Way split cutlery basket			
Upper rack height adjustment			
Upper rack number of shelves	4	4	4
Upper rack shelf height adjustment	•	•	•
<b>PROGRAMS</b>			
1	Prewash	Prewash	Prewash
2	Mini 30' 35°C	Mini 30' 35°C	Eco 50°C
3	Eco 50°C	Eco 50°C	Intensive 65°C
4	Quick&Clean 60°C	Quick&Clean 60°C	
5	Intensive 70°C	Intensive 70°C	
6			
7			
8			

[DSN 6839 FX](#) | [DSN 6839 FXExtra](#) | [DSN 6838 X](#) | [DSN 6834 FX](#) | [DSN 6833 X](#) | [DSN 6834 X Extra](#)  
[DSN 6834 B Extra](#) | [DSN 6834 Extra](#) | [DSN 6534 FX](#) | [DSN 6533 X](#) | [DSN 4530 FX](#) | [DSN 6533 X](#)  
[DSN 4530 FX](#) | [DSN 2521 X](#) | [DSN 2521 B](#) | [DSN 2521](#) | [DSN 2501 X](#) | [DSN 2521 B](#) | [DSN 2521](#)  
[DSN 2501 X](#) | [DSN 1521 X](#) | [DSN 1501 X](#) | [DSN 1421 X](#) | [DSN 1401 X](#) | [DSN 1321 X](#) | [DSN 1301X](#)  
[DSN 1301 XP](#) | [DSN 1301 B](#) | [DSN 1301](#) | [DIN 5832](#) | [DIN 5832 Extra](#) | [DDN 5832 X](#) | [DDN 5832 Extra](#)

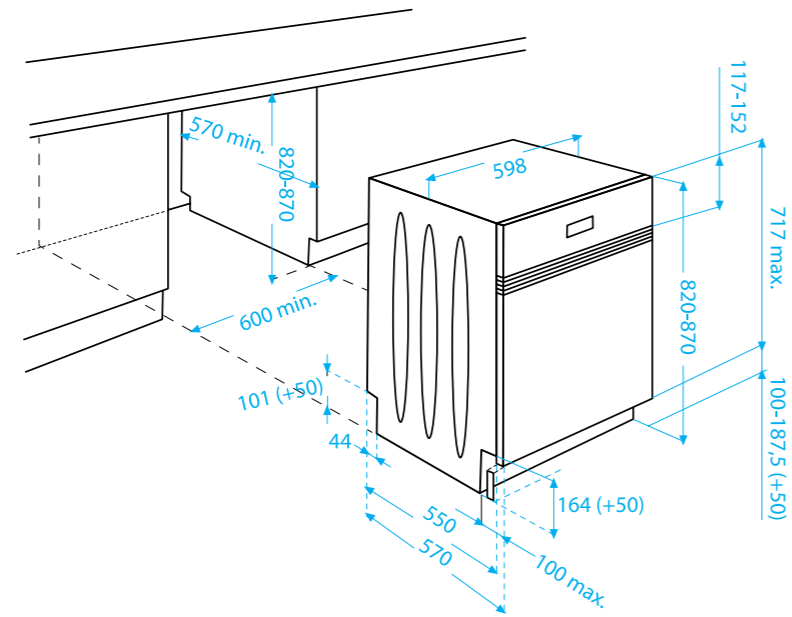

[DIS 1501](#) | [DIS 1300](#)

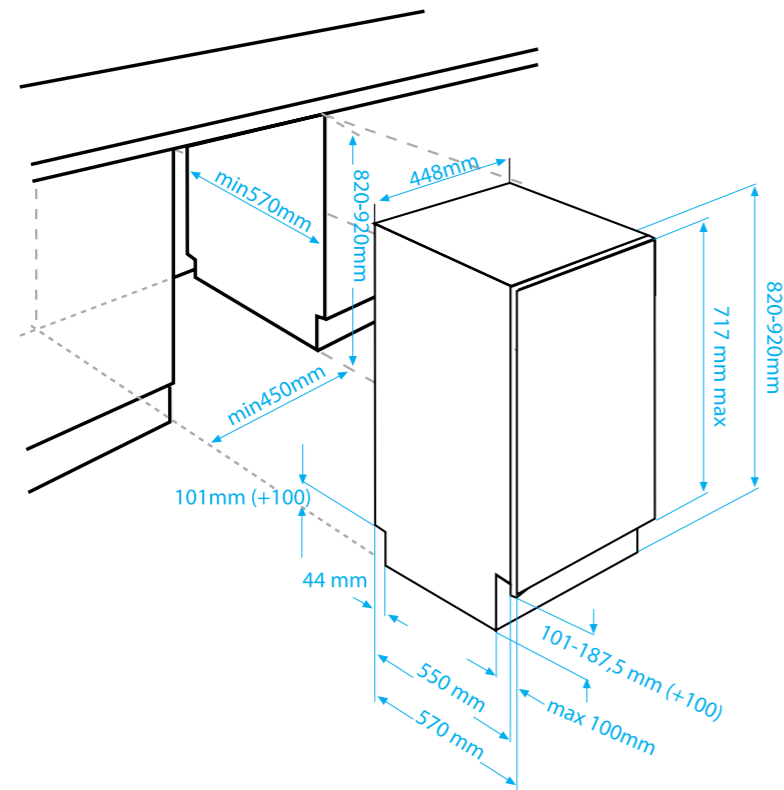

[DIN 5832 XL](#) | [DDN 5832 XXL](#)

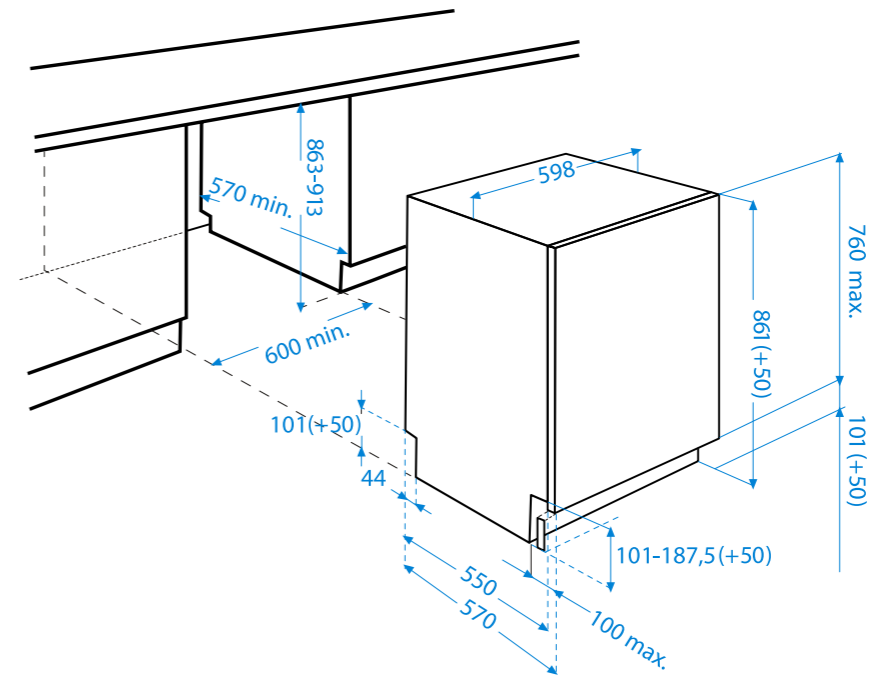

[DSS 6630 X](#) | [DSS 6830 X](#) | [DSS 2521 X](#) | [DSS 2501 X](#) | [DSS 2501 XP](#) | [DSS 1301 X](#) | [DSS 1301 XP](#)

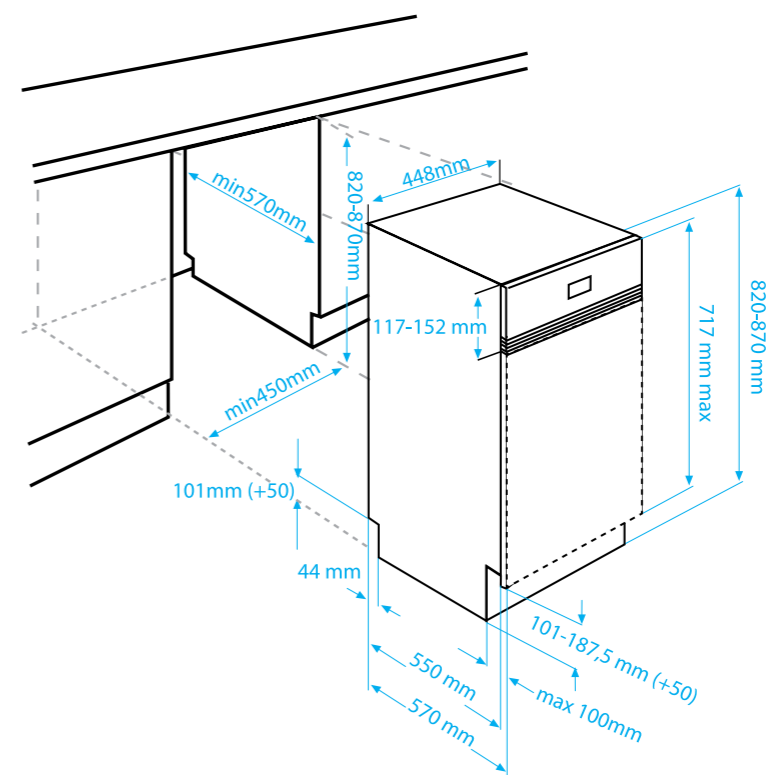

# Refrigerators & Freezers

## Built-In Refrigerators & Freezers



MODEL CODE	CBI 7771	CBI 7730	CBI 7701	CBI 7700 HCA
<b>CAPACITY</b>				
Fresh food net volume (lt)	193	155	180	189
Freezer net volume (lt)	49	62	55	55
<b>PERFORMANCE</b>				
Star rating	****	****		****
Climatic class	SN-T	SN	SN-ST	SN
Energy efficiency class	A+	A	A+	A
Energy consumption (kWhr/24 hr)	0.75	0.825	0.756	0.814
Freezing capacity (kg/24 hr)	2.5	3.5	4	4
Temperature recovery time (hr)	13	13	20	20
Control system	Mechanic	Mechanic	Electronic	Mechanic
Cooling system	No frost	No frost	Static	Conventional
Refrigerant	R600a	R600a	R600a	R600a
<b>ENERGY CONNECTIONS</b>				
Voltage (V)	230	230	230	230
Frequency (Hz)	50	50	50	50
Maximum current intensity (A)	0.6	0.5	0.35	0.5
Cable length (m)	1.93	1.93	1.93	1.93
<b>DIMENSIONS</b>				
Niche dimensions (hxwx d) (cm)	178,9x56x55	178,9x56x55	178,9x56x55	178,9x56x55
Product dimensions (hxwx d) (cm)	177x54x53,5	177x54x53,5	177x54x53,5	177x54x53,5
Packed dimensions (hxwx d) (cm)	184x57,5x56,5	184x57,5x56,5	184x57,5x56,5	184x57,5x56,5
Gross weight (kg)	69	63	63	63
Net weight (kg)	62	58	58	58
<b>FRESH FOOD COMPARTMENT</b>				
0 °C compartment	-	-	•	-
Active odour filter	-	-	-	-
Active ioniser	-	-	-	-
Silver protection	•	•	•	•
Active seal guard	-	-	-	-
Active fresh blue light	-	-	-	-
Interior light	•	•	•	•
Crisper (type/qty)	Standard/2	Standard/2	Standard/1	Standard/2
Shelves (type/qty)	Glass/4	Glass/3	Glass/4	Glass/4
Bottle rack	•	•	•	-
Bottle holder	-	-	-	•
Door racks (type/qty)	Full width/4	Full width/3	Full width/4	Full width/4
Tilt-out bins under door rack (qty)	-	-	-	-
Dairy compartment	-	-	-	-
Egg trays (qty)	1	1	1	1
Stored water dispenser	-	-	-	-
Snack drawer	-	-	-	-
<b>FREEZER COMPARTMENT</b>				
Interior light	-	-	-	-
Icebank & icecube tray	-	-	-	-
Icecube tray	•	•	•	•
Twist & serve icecube tray	-	-	-	-
Water & ice dispenser	-	-	-	-
Fresh freezing compartment	-	-	-	-
Number of freezer compartments	3	4	3	3

## Built-In Refrigerators & Freezers



MODEL CODE	CBI 7740	RBI 6301	RBI 6300 HCA	RBI 6100 HCA
<b>CAPACITY</b>				
Fresh food net volume (lt)	155	170	170	125
Freezer net volume (lt)	69	45	45	45
<b>PERFORMANCE</b>				
Star rating	****	****	****	****
Climatic class	SN	SN-ST	SN	SN
Energy efficiency class	A	A+	A	A
Energy consumption (kWhr/24 hr)	0.81	0.636	0.767	0.71
Freezing capacity (kg/24 hr)	4	4	4	4
Temperature recovery time (hr)	14	23	23	19
Control system	Mechanic	Mechanic	Mechanic	Mechanic
Cooling system	Conventional	Conventional	Conventional	Conventional
Refrigerant	R600a	R600a	R600a	R600a
<b>ENERGY CONNECTIONS</b>				
Voltage (V)	230	230	230	230
Frequency (Hz)	50	50	50	50
Maximum current intensity (A)	0.5	0.28	0.28	0.4
Cable length (m)	1.93	1.93	1.93	1.93
<b>DIMENSIONS</b>				
Niche dimensions (hxwx) (cm)	178,9x56x55	145-146x56x55	145-146x56x55	121,6-122,9x56x55
Product dimensions (hxwx) (cm)	177x54x53,5	144x54x53,5	144x54x53,5	121x54x53,5
Packed dimensions (hxwx) (cm)	184x57,5x56,5	151,5x57,5x56,5	151,5x57,5x56,5	128x57,5x56,5
Gross weight (kg)	63	49	49	43
Net weight (kg)	58	44	44	39
<b>FRESH FOOD COMPARTMENT</b>				
0 °C compartment	-	-	-	-
Active odour filter	-	-	-	-
Active ioniser	-	-	-	-
Silver protection	•	•	•	•
Active seal guard	-	-	-	-
Active fresh blue light	-	-	-	-
Interior light	•	•	•	•
Crisper (type/qty)	Standard/2	Standard/2	Standard/2	Standard/1
Shelves (type/qty)	Glass/3	Glass/3	Glass/3	Glass/2
Bottle rack	•	•	-	-
Bottle holder	-	-	•	•
Door racks (type/qty)	Full width/3	Full width/3	Full width/3	Full width/3
Tilt-out bins under door rack (qty)	-	-	-	-
Dairy compartment	-	-	-	-
Egg trays (qty)	1	1	1	1
Stored water dispenser	-	-	-	-
Snack drawer	-	-	-	-
<b>FREEZER COMPARTMENT</b>				
Interior light	-	-	-	-
Icebank & icecube tray	-	-	-	-
Icecube tray	•	•	•	•
Twist & serve icecube tray	-	-	-	-
Water & ice dispenser	-	-	-	-
Fresh freezing compartment	-	-	-	-
Number of freezer compartments	4	-	-	-

## Built-In Refrigerators & Freezers

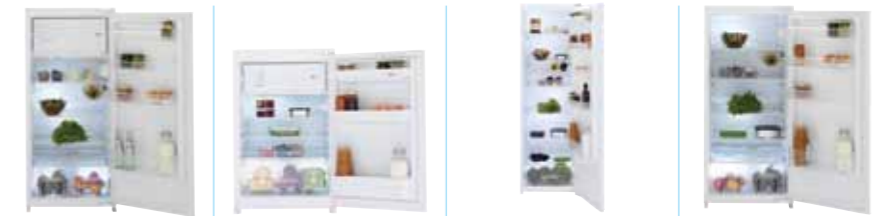

MODEL CODE	RBI 2300 HCA	B 1751	LBI 3000 HCA	LBI 2200 HCA
<b>CAPACITY</b>				
Fresh food net volume (lt)	164	97	310	204
Freezer net volume (lt)	20	13	-	-
<b>PERFORMANCE</b>				
Star rating	****	****	-	-
Climatic class	SN	SN	SN-T	SN
Energy efficiency class	A	A+	A	A
Energy consumption (kWhr/24 hr)	0.696	0.482	0.477	0.436
Freezing capacity (kg/24 hr)	3	2	-	-
Temperature recovery time (hr)	16	10	-	-
Control system	Mechanic	Mechanic	Mechanic	Mechanic
Cooling system	Conventional	Conventional	Conventional	Conventional
Refrigerant	R600a	R600a	R600a	R600a
<b>ENERGY CONNECTIONS</b>				
Voltage (V)	230	230	230	230
Frequency (Hz)	50	50	50	50
Maximum current intensity (A)	0.29	0.5	0.45	0.29
Cable length (m)	1.93	1.93	1.93	1.93
<b>DIMENSIONS</b>				
Niche dimensions (hxwx) (cm)	121,6-122,9x56x55	88x56x55	178x56x55	121,6-122,9x56x55
Product dimensions (hxwx) (cm)	121x54x53,5	86x54x54,8	176,5x54x53,5	121x54x53,5
Packed dimensions (hxwx) (cm)	128x57,5x56,5	89,5x60x57,5	183x57,5x56,5	128x57,5x56,5
Gross weight (kg)	42	33,5	50	40
Net weight (kg)	38	31,5	47	36
<b>FRESH FOOD COMPARTMENT</b>				
0 °C compartment	-	-	-	-
Active odour filter	-	-	-	-
Active ioniser	-	-	-	-
Silver protection	•	•	•	•
Active seal guard	-	-	-	-
Active fresh blue light	-	-	-	-
Interior light	•	•	•	•
Crisper (type/qty)	Standard/1	Standard/1	Standard/1	Standard/1
Shelves (type/qty)	Glass/3	Glass/2	Glass/5	Glass/4
Bottle rack	-	-		-
Bottle holder	•	-	-	
Door racks (type/qty)	Full width/4	Full width/3	Full width/5	Full width/4
Tilt-out bins under door rack (qty)	-	-	-	-
Dairy compartment	-	-	-	-
Egg trays (qty)	1	1	1	1
Stored water dispenser	-	-	-	-
Snack drawer	-	-	-	-
<b>FREEZER COMPARTMENT</b>				
Interior light	-	-	-	-
Icebank & icecube tray	-	-	-	-
Icecube tray	•	•	•	•
Twist & serve icecube tray	-	-	-	-
Water & ice dispenser	-	-	-	-
Fresh freezing compartment	-	-	-	-
Number of freezer compartments	-	-	-	-



## Built-In Refrigerators & Freezers



MODEL CODE	B 1801	BU 1150 HCA	BU 1100 HCA	FBI 5850
<b>CAPACITY</b>				
Fresh food net volume (lt)	126	105	128	-
Freezer net volume (lt)	-	18	-	196
<b>PERFORMANCE</b>				
Star rating	-	****	-	****
Climatic class	SN-T	SN	SN	SN-T
Energy efficiency class	A+	A	A	A+
Energy consumption (kWhr/24 hr)	0.331	0.658	0.413	0.814
Freezing capacity (kg/24 hr)	-	2	-	10
Temperature recovery time (hr)	-	10	-	15
Control system	Mechanic	Mechanic	Mechanic	Mechanic
Cooling system	Conventional	Conventional	Conventional	No frost
Refrigerant	R600a	R600a	R600a	R600a
<b>ENERGY CONNECTIONS</b>				
Voltage (V)	230	230	230	230
Frequency (Hz)	50	50	50	50
Maximum current intensity (A)	0.5	0.35	0.21	0.5
Cable length (m)	1.93	1.93	1.93	1.93
<b>DIMENSIONS</b>				
Niche dimensions (hxwx d) (cm)	88x56x55	82-88x60x55	82-88x60x55	178x56x55
Product dimensions (hxwx d) (cm)	86x54x54,8	82x59,8x54,5	82x59,8x54,5	176,5x54x53,5
Packed dimensions (hxwx d) (cm)	89,5x60x57,5	88x63x57,5	88x63x57,5	183x57,5x56,5
Gross weight (kg)	33	35	33	62
Net weight (kg)	31	32	30	56
<b>FRESH FOOD COMPARTMENT</b>				
0 °C compartment	-	-	-	-
Active odour filter	-	-	-	-
Active ioniser	-	-	-	-
Silver protection	-	-	-	-
Active seal guard	-	-	-	-
Active fresh blue light	-	-	-	-
Interior light	-	-	-	-
Crisper (type/qty)	Standard/1	Basket/1	Basket/1	-
Shelves (type/qty)	Glass/3	Glass/2	Glass/3	-
Bottle rack	-	-	-	-
Bottle holder	-	-	-	-
Door racks (type/qty)	Full width/3	Full width/2	Full width/2	-
Tilt-out bins under door rack (qty)	-	-	-	-
Dairy compartment	-	-	-	-
Egg trays (qty)	1	1	1	-
Stored water dispenser	-	-	-	-
Snack drawer	-	-	-	-
<b>FREEZER COMPARTMENT</b>				
Interior light	-	-	-	-
Icebank & icecube tray	-	1	-	-
Icecube tray	-	-	-	-
Twist & serve icecube tray	-	-	-	-
Water & ice dispenser	-	-	-	-
Fresh freezing compartment	-	-	-	-
Number of freezer compartments	-	-	-	8

## Built-In Refrigerators & Freezers



MODEL CODE	B 1940	B 1901	BU 1200 HCA	WBI 1200
<b>CAPACITY</b>				
Fresh food net volume (lt)	-	-	-	36 Bottles
Freezer net volume (lt)	75	85	87	-
<b>PERFORMANCE</b>				
Star rating	****	****	****	-
Climatic class	SN	SN-T	SN	SN
Energy efficiency class	A	A+	A	-
Energy consumption (kWhr/24 hr)	0.567	0.524	0.562	0.569
Freezing capacity (kg/24 hr)	10	10	10	-
Temperature recovery time (hr)	10.5	20	19	-
Control system	Mechanic	Electronic	Electronic	Electronic
Cooling system	No frost	Conventional	Conventional	Conventional
Refrigerant	R600a	R600a	R600a	R600a
<b>ENERGY CONNECTIONS</b>				
Voltage (V)	230	230	230	230
Frequency (Hz)	50	50	50	50
Maximum current intensity (A)	0.5	0.5	0.24	0.25
Cable length (m)	1.93	1.93	1.93	1.93
<b>DIMENSIONS</b>				
Niche dimensions (hxwx d) (cm)	88x56x55	88x56x55	82-88x60x55	88x56x55
Product dimensions (hxwx d) (cm)	86x54x54,8	86x54x54,8	82x59,8x54,5	86,5x54x52,5
Packed dimensions (hxwx d) (cm)	89,5x60x57,5	89,5x60x57,5	88x63x57,5	95,5x57,5x63
Gross weight (kg)	33	33	36	32
Net weight (kg)	31	31	33	30
<b>FRESH FOOD COMPARTMENT</b>				
0 °C compartment	-	-	-	-
Active odour filter	-	-	-	-
Active ioniser	-	-	-	-
Silver protection	-	-	-	-
Active seal guard	-	-	-	-
Active fresh blue light	-	-	-	-
Interior light	-	-	-	-
Crisper (type/qty)	-	-	-	-
Shelves (type/qty)	-	-	-	Wooden/4
Bottle rack	-	-	-	-
Bottle holder	-	-	-	-
Door racks (type/qty)	-	-	-	-
Tilt-out bins under door rack (qty)	-	-	-	-
Dairy compartment	-	-	-	-
Egg trays (qty)	-	-	-	-
Stored water dispenser	-	-	-	-
Snack drawer	-	-	-	-
<b>FREEZER COMPARTMENT</b>				
Interior light	-	-	-	-
Icebank & icecube tray	-	-	-	-
Icecube tray	-	-	-	-
Twist & serve icecube tray	-	-	-	-
Water & ice dispenser	-	-	-	-
Fresh freezing compartment	-	-	-	-
Number of freezer compartments	3	3	3	-

## Built-In Refrigerators & Freezers



MODEL CODE	BUDL 700	BUDZ 700
<b>CAPACITY</b>		
Fresh food net volume (lt)	94	-
Freezer net volume (lt)	-	72
<b>PERFORMANCE</b>		
Star rating	-	****
Climatic class	SN-T	SN-T
Energy efficiency class	A	A
Energy consumption (kWhr/24 hr)	0.375	0.87
Freezing capacity (kg/24 hr)	-	6
Temperature recovery time (hr)	-	9
Control system	Electronic	Electronic
Cooling system	Conventional	No frost
Refrigerant	R600a	R600a
<b>ENERGY CONNECTIONS</b>		
Voltage (V)	230	230
Frequency (Hz)	50	50
Maximum current intensity (A)	0.35	0.35
Cable length (m)	1.93	1.93
<b>DIMENSIONS</b>		
Niche dimensions (hxwx) (cm)	82-87x60x55	82-87x60x55
Product dimensions (hxwx) (cm)	81,3-86,3x59,8x54,5	81,3-86,3x59,8x54,5
Packed dimensions (hxwx) (cm)	88x63x57,5	88x63x57,5
Gross weight (kg)	33	33
Net weight (kg)	30	30
<b>FRESH FOOD COMPARTMENT</b>		
0 °C compartment	-	-
Active odour filter	-	-
Active ioniser	-	-
Silver protection	-	-
Active seal guard	-	-
Active fresh blue light	-	-
Interior light	-	-
Crisper (type/qty)	Drawer	-
Shelves (type/qty)	-	-
Bottle rack	-	-
Bottle holder	-	-
Door racks (type/qty)	-	-
Tilt-out bins under door rack (qty)	-	-
Dairy compartment	-	-
Egg trays (qty)	-	-
Stored water dispenser	-	-
Snack drawer	-	-
<b>FREEZER COMPARTMENT</b>		
Interior light	-	-
Icebank & icecube tray	-	-
Icecube tray	-	-
Twist & serve icecube tray	-	-
Water & ice dispenser	-	-
Fresh freezing compartment	-	-
Number of freezer compartments	-	2

## SBS in BI Style



MODEL CODE	BEKO 4 MORE	GNE 45730 FX	GNE 45720 P	GNE 35730 FX
Type	4 Door side by side fridge freezer	Side by side fridge freezer	Side by side fridge freezer	Side by side fridge freezer
Color	Fingerprint stainless steel	Fingerprint stainless steel	Piano black	Fingerprint stainless steel
<b>CAPACITY</b>				
Total volume gross (lt)	610	573	573	573
Fresh food compartment volume net (lt)	380	383	383	383
Freezer compartment volume net (lt)	184	146	185	152
<b>PERFORMANCE</b>				
Star rating	****	****	****	****
Climatic class	SN/T	SN	SN	SN
Energy efficiency class	A	A	A	A
Energy consumption (kWhr/24hr)	1,511	1,449	1,449	1,449
Freezing capacity (kg/24hr)	10	13	13	13
Temperature recovery time (hr)	6	8	8	8
Control system	Electronic	Electronic	Electronic	Electronic
Cooling system	Frost Free	Frost Free	Frost free	Frost free
Refrigerant	R600a	R134a	R134a	R134a
<b>ENERGY CONNECTIONS</b>				
Voltage (V)	230	230	230	230
Frequency (Hz)	50	50	50	50
Maximum current intensity (A)	0.90	0.65	0.65	0.65
Cable length (m)	1,930	1,930	1,930	1,930
<b>DIMENSIONS</b>				
Height (cm)	182	177.5	177.5	177.5
Width (cm)	92	92.5	92.5	92.5
Depth (cm)	76.5	74	74	74
Packed dimensions (hxwx) (cm)	191.5x99x77.5	189x99x77.5	189x99x77.5	189x99x77.5
<b>SPECIFICATIONS</b>				
Fridge compartment				
0 °C compartment	•	•	•	•
Active odour filter	•	•	•	•
Active ioniser	•	•	•	•
Silver protection	•	•	•	•
Active seal guard	•	•	•	•
Active fresh blue light	•	•	•	•
Crisper (type/qty)	Sliding/2	Sliding/2	Sliding/2	Sliding/2
Shelves (type/qty)	Glass/3	Glass/5	Glass/5	Glass/5
Bottle rack	-	•	•	•
Door racks (type/qty)	Full width/8	Full width/4	Full width/4	Full width/5
Dairy compartment	•	•	•	•
Egg trays (qty)	2	2	2	2
Stored water dispenser	-	-	-	-
Snack drawer	-	•	•	-
Freezer compartment				
Interior light	-	•	•	•
Icebank & icecube tray	-	-	-	-
Icecube tray	-	-	-	-
Twist & serve icecube tray	•	-	-	-
Water & ice dispenser	-	•	•	•
Fresh freezing compartment (qty)	•	•	•	•
Freezer compartment numbers	6	3	3	5 (incl. 3 drawers)

## SBS in BI Style



MODEL CODE	GNE 25800 X
Type	Side by side fridge freezer
Color	Stainless steel
<b>CAPACITY</b>	
Total volume gross (lt)	573
Fresh food compartment volume net (lt)	375
Freezer compartment volume net (lt)	179
<b>PERFORMANCE</b>	
Star rating	****
Climatic class	SN/T
Energy efficiency class	A
Energy consumption (kWhr/24hr)	1,523
Freezing capacity (kg/24hr)	13
Temperature recovery time (hr)	8
Control system	Electronic
Cooling system	Frost free
Refrigerant	R134a
<b>ENERGY CONNECTIONS</b>	
Voltage (V)	230
Frequency (Hz)	50
Maximum current intensity (A)	0.60
Cable length (m)	1,930
<b>DIMENSIONS</b>	
Height (cm)	177.5
Width (cm)	92.5
Depth (cm)	74
Packed dimensions (hxwx d) (cm)	189x99x77.5
<b>SPECIFICATIONS</b>	
Fridge compartment	
0 °C compartment	•
Active odour filter	•
Active ioniser	•
Silver protection	•
Active seal guard	•
Active fresh blue light	•
Crisper (type/qty)	Sliding/2
Shelves (type/qty)	Glass/5
Bottle rack	•
Door racks (type/qty)	Full width/4
Dairy compartment	•
Egg trays (qty)	2
Stored water dispenser	•
Snack drawer	•
Freezer compartment	
Interior light	•
Icebank & icecube tray	-
Icecube tray	-
Twist & serve icecube tray	•
Water & ice dispenser	-
Fresh freezing compartment (qty)	-
Freezer compartment numbers	6 (incl. 2 drawers)

## Fridge Freezers in BI Style



MODEL CODE	DNE 65500 DPX	DNE 47560 DS	DNE 50420 X	DNE 47020 X
Type	Full Frost free double door/ fridge freezer	Full Frost free double door/ fridge freezer	Frost Free double door fridge freezer	Full frost free double door fridge freezer
Color	Iridium stainless steel	Iridium stainless steel	Stainless steel	Stainless steel
<b>CAPACITY</b>				
Total volume gross (lt)	650	470	500	465
Fresh food compartment volume net (lt)	392	350	355	325
Freezer compartment volume net (lt)	143	90	90	90
<b>PERFORMANCE</b>				
Star rating	****	****	****	****
Climatic class	T	SN-T	SN-T	SN-T
Energy efficiency class	A	A+	A+	A+
Energy consumption (kWhr/24hr)	1.438	1.219	1.036	0.945
Freezing capacity (kg/24hr)	10	5	6	6
Temperature recovery time (hr)	17	8	14	8
Control system	Electronic	Electronic	Mechanic	Mechanic
Cooling system	Frost free	Frost free	Frost free	Frost free
Refrigerant	R600a	R134a	R600a	R134a
<b>ENERGY CONNECTIONS</b>				
Voltage (V)	220-240	220-240	220	220-240
Frequency (Hz)	50	50	50	50
Maximum current intensity (A)	0.89	0.82	-	0.75
Cable length (m)	1.93	1.93	-	1.93
<b>DIMENSIONS</b>				
Height (cm)	183.5	191.5	189	179
Width (cm)	84	70	70	70
Depth (cm)	74.5	68	68	68
Packed dimensions (hxwx d) (cm)	188,5x91x77,5	196x77x77	196x75x77	186x77x77
<b>SPECIFICATIONS</b>				
Door opening	-	Reversible	Reversible	Reversible
Indicator light	-	-	-	-
Electronic display	•	•	-	-
Water dispenser	•	•	-	-
Fridge compartment				
Biofresh/0°C compartment	•	•	-	-
Fan	-	-	-	-
Active odour filter	•	•	•	•
Active Ioniser	•	•	-	-
Silver protection	•	•	-	-
Light	•	•	•	•
Crisper (type/qty)	Sliding/3	Rotating/1	rotating/1	Rotating/1
Shelves (type/qty)	Glass/3	Glass/4	Glass/4	Glass/3
Bottle holder	-	-	•	•
Bottle rack	•	•	-	-
Door racks (type/qty)	2 full & 2 half width	4 half & 3 Full width	5 full width	4 Full width
Tilt out bins under door rack (qty)	-	3	3	3
Dairy compartment	-	-	-	-
Egg trays (qty)	2	2	2	2
Defrost	Auto	Auto	Auto	Auto
Freezer compartment				
Icebank	Twist&Serve ice cube tray	Twist&Serve ice cube tray	-	Twist&Serve ice cube tray
Ice cube tray (qty)	-	-	-	-
Shelves (type/qty)	Plastic/1	Plastic/1	Plastic/1	Plastic/1
Door racks (type/qty)	Full width/2	Full width/2	Full width/2	Full width/2
Compartment (type/qty)	Fresh freeze	-	-	-

# Fridge Freezers in BI Style



MODEL CODE	DNE 43020 X	CNE 32100 X	CHE 42200 DPX	CSE 34000 X
Type	Full Frost free double door fridge freezer	Full Frost free combi fridge freezer	Combi fridge freezer	Combi fridge freezer
Color	Stainless steel	Fingerprint stainless steel	Iridium stainless seel	Fingerprint stainless steel
<b>CAPACITY</b>				
Total volume gross (lt)	430	320	420	340
Fresh food compartment volume net (lt)	295	205	298	205
Freezer compartment volume net (lt)	90	68	86	78
<b>PERFORMANCE</b>				
Star rating	****	****	****	****
Climatic class	SN-T	SN	SN	SN
Energy efficiency class	A+	A	A	A
Energy consumption (kWhr/24hr)	0.912	0.947	1.063	0.898
Freezing capacity (kg/24hr)	6	8	4	5
Temperature recovery time (hr)	14	15	17	21
Control system	Mechanic	Electronic	Mechanic	Mechanic
Cooling system	Frost free	Frost free	Semi Frost free	Static
Refrigerant	R600a	R600a	R600a	R600a
<b>ENERGY CONNECTIONS</b>				
Voltage (V)	230	230	230	230
Frequency (Hz)	50	50	50	50
Maximum current intensity (A)	0.54	0.32	0.38	0.44
Cable length (m)	1.93	1.93	1.93	1.93
<b>DIMENSIONS</b>				
Height (cm)	169	184.5	191	184.5
Width (cm)	70	60	70	60
Depth (cm)	68	60	62.5	60
Packed dimensions (hxwx d) (cm)	176x77x77	193,5x66,5x68	198x77x70,5	193,5x66,5x68
<b>SPECIFICATIONS</b>				
Door opening	Reversible	Reversible	Reversible	Reversible
Indicator light	-	-	-	-
Electronic display	-	-	-	-
Water dispenser	-	-	-	-
Fridge compartment	-	-	-	-
Biofresh/0°C compartment	-	-	-	-
Fan	-	-	-	-
Active odour filter	-	-	-	-
Active Ioniser	-	-	-	-
Silver protection	-	-	-	-
Light	-	-	-	-
Crisper (type/qty)	Rotating/1	standard/2	standard/2	standard/2
Shelves (type/qty)	Glass/3	Glass/3	Glass/4	Glass/3
Bottle holder	-	-	-	-
Bottle rack	-	-	-	-
Door racks (type/qty)	4 Full width	4 Full width	2 half & 3 Full width	4 Full width
Tilt out bins under door rack (qty)	3	2	-	2
Dairy compartment	-	-	-	-
Egg trays (qty)	2	1	2	1
Defrost	Auto	Auto	Auto	Auto
Freezer compartment	-	-	-	-
Icebank	-	-	Twist&Serve ice cube tray	-
Ice cube tray (qty)	1	1	2	1
Shelves (type/qty)	Plastic/1	-	-	-
Door racks (type/qty)	Full width/2	-	-	-
Compartment (type/qty)	-	Plastic/3	Plastic/3	Plastic/3

CBI 7771 | CBI 7701 | CBI 7700 HCA

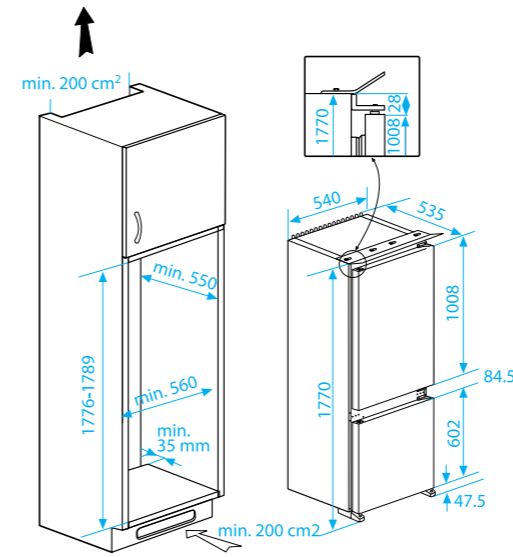

CBI 7730 | CBI 7740

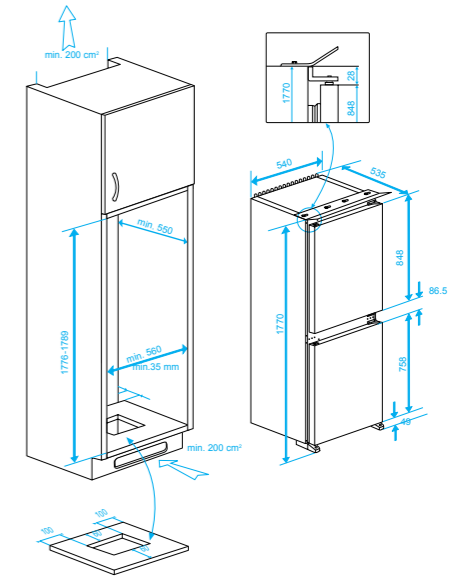

RBI 6300 HCA | RBI 6301

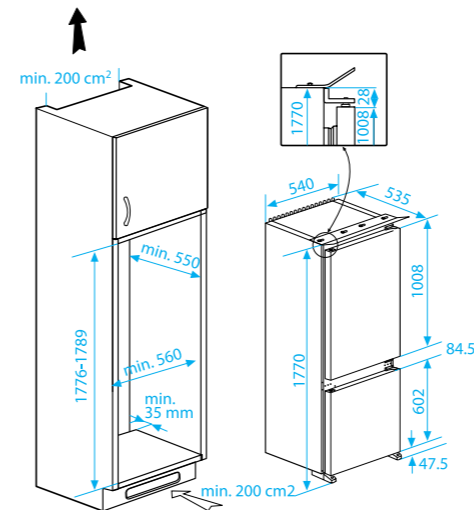

RBI 6100 HCA

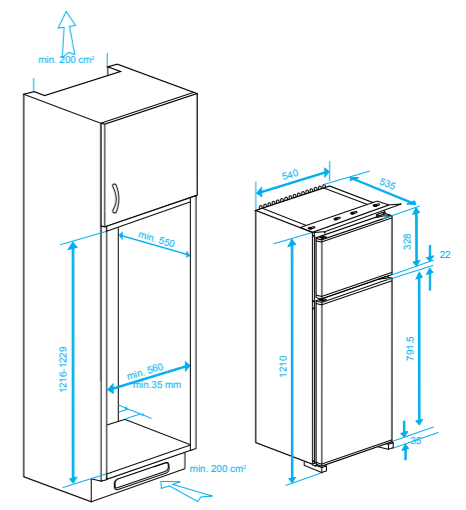

RBI 2300 HCA | LBI 2200 HCA

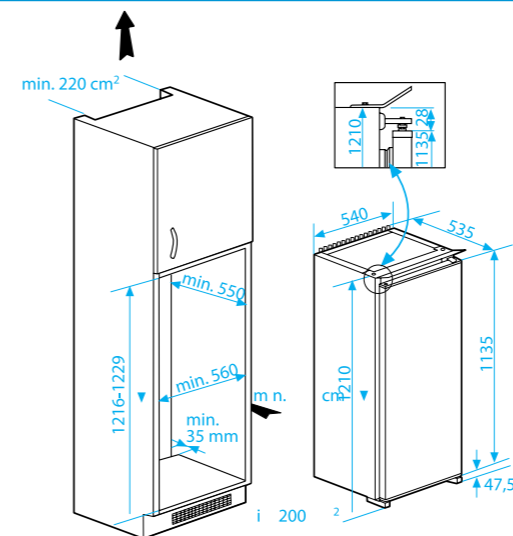

BUDL 700 | BUDF 700

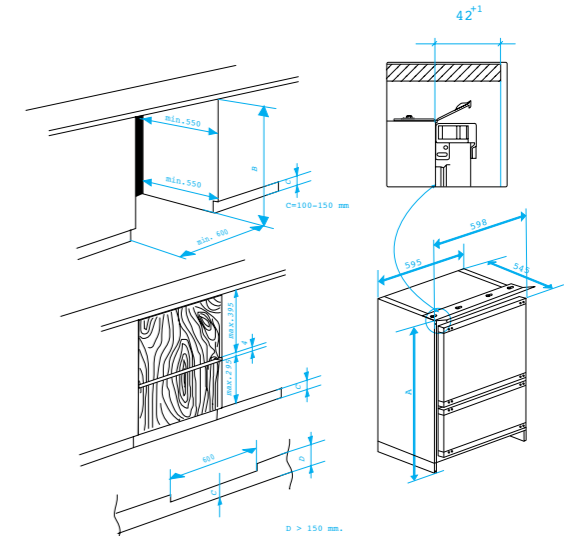

B 1750 HCA | B 1751 | B 1800 HCA | B 1801  
 B 1900 HCA | B 1901 | B 1940

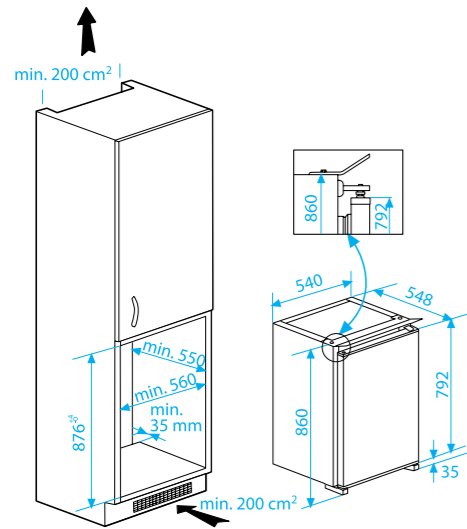

LBI 3000 HCA | FBI 5850

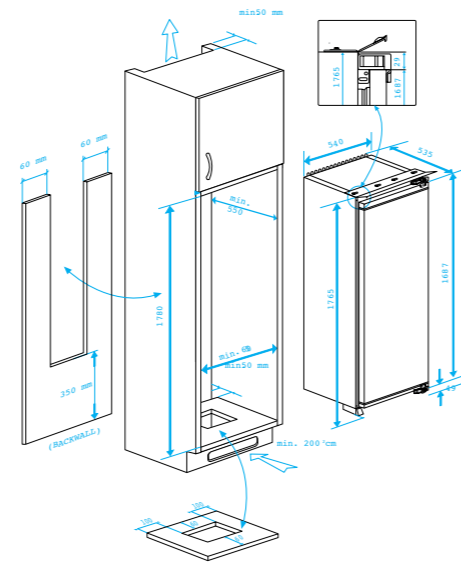

WBI 1200

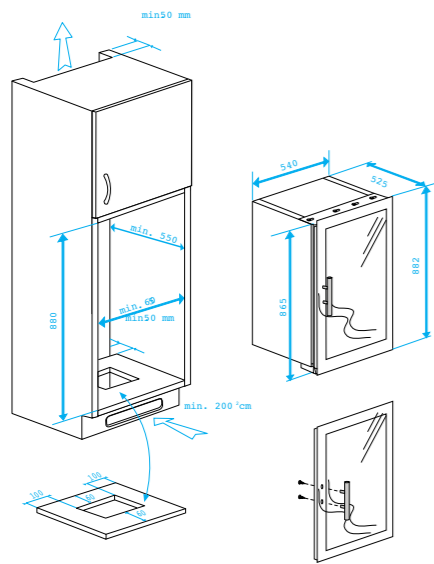

BU 1150 HCA | BU 1200 HCA | BU 1100 HCA

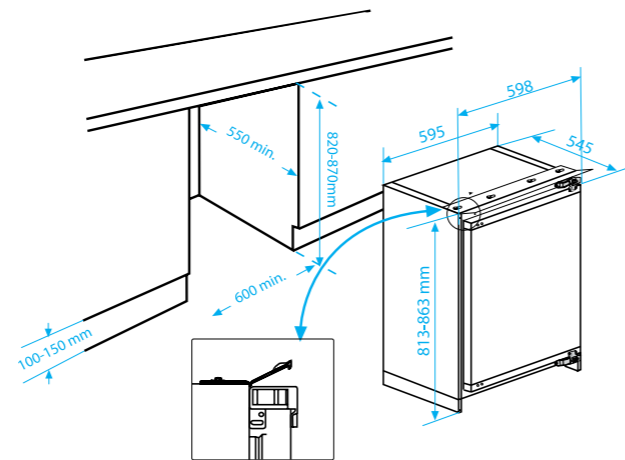

Due to continual improvements through research and development, Beko reserves the right to make any changes to the specifications and features of the products without prior notice. As a result, you may find differences between the products described in the catalogue and the product you receive. Beko can not be held responsible for printing mistakes.